



INSTRUCTIONS FOR USE

Rultract, Inc.

5663 Brecksville Rd. Cleveland, Ohio 44131-1593 U.S.A.
PH:(888) 550-5695
E-Mail: rultract@rultract.com Website: www.rultract.com

Caution: Federal Law (USA) restricts this device to sale by or on the order of a physician.

Important

The Rultract® Skyhook Retractor is to be used according to the instructions for use. All personnel who handle Rultract® device must read these instructions prior to use of the instrument.

DEVICE DESCRIPTION

The Rultract® Skyhook Retractor is a manual surgical instrument system intended for use in surgery under sterile conditions. The Rultract® Skyhook Retractor System is designed as an omni-positioning retractor instrument to elevate, position, and stabilize surgical sites and tissue, and provide optimal surgical exposure and stability. The wide selection of base (table) arms and clamps, cross-member components, and propriety Rultract Skyhook Retractor assembly, make the Rultract product line suitable for any surgical specialty and application.

INTENDED USE

The Rultract® Skyhook Retractor assembly is a manual surgical instrument intended for use in surgery to facilitate access to surgical sites under sterile conditions by the direction of the surgeon.

CONTRAINDICATIONS

There are no known contraindications to Rultract® Skyhook Retractors.



Rultract, Inc. 5663 Brecksville Rd.
Cleveland, Ohio 44131 U.S.A.

Table of Contents / Warnings Index		Cable Replacement Instructions	24-29
Standards of Safe Use	02	SPD Cleaning Instructions / Guidelines (Biocompatibility)	30-35
Precautions Index	03	SPD Sterilization Guidelines and Parameters	36
Operating Room IFU	04-07	SPD Instructions Prepare for Sterilization	37-41
Resternotomy Attachments OR IFU	08-09	Parts List	42
O R Table Rail Mounted Clamp IFU	10-13	Additional Service Information And Warnings	43
Top and Bottom Posts IFU	14-20		
Extender Bar(s) IFU	21-23		

WARNINGS INDEX — Standards of Safe Use Compliance
PROPER SERVICING AND REPAIR OF YOUR RULTRACT RETRACTOR SYSTEM

Rultract, Inc. is the ONLY authorized service center in the U.S.A.

SERVICE INTERVAL: Complete factory service of your Rultract Skyhook Retractor System (including a cable change):

****If using a surgical device tracking system to track cases, i.e. Censitrac: 400 cases.**

****If not using a surgical device tracking system to track cases, i.e. Censitrac: Every 12-24 months dependent on frequency of use.**

WARNING: Cables worn or damaged through mishandling *prior to the factory service interval*, must be replaced with a new Rultract® cable. Do not attempt to repair, cut, alter or modify the cable in any way. **Cutting and reattaching the cable will cause it to weaken and fray. This will result in failure during use.**

Contact Rultract at service@rultract.com or 888-550-5695 to schedule service/repair or with questions concerning routine maintenance and service.

Use only Rultract OEM parts and service as provided at the factory authorized Rultract service center. Failure to do so could put the hospital, operating room staff and patient at risk.

USING OUTSIDE SERVICE VENDORS TO SERVICE/REPAIR YOUR RULTRACT RETRACTOR: Rultract is the only authorized service center for the Rultract Retractor System. Outside service vendors are not authorized to service or repair the Rultract Retractor System and do not have access to all Rultract OEM replacement parts.

Using outside service vendors to service/repair your Rultract retractor system will void all current warranties, and could put the hospital, operating room staff and patient at risk.

REPLACEMENT: Rultract Ratchet Assemblies and Rake Plate Assemblies purchased prior to 2000, with no OEM maintenance history or relevant product update history, require replacement.

WARNING:

Any modification or alteration to a Rultract® product by user will void all warranties and release Rultract® from any liability.

PRECAUTIONS INDEX

CAUTION: Check and tighten all fasteners on the Ratchet/Rake Assembly. Failure to do so may result in components to loosen or disassemble during use (see p. 39).

CAUTION: Do not remove retaining Roll Pins *(4100P-18) and ***(4100P-16), (see p. 39).

CAUTION: Hand tighten Lock Knob and Spool Cap Nut securely (see p. 04, 21-24, 30, 42).

CAUTION: Lock Knob **MUST** be inserted in a detent for secure placement of accessories (see p. 04, 21-24)

CAUTION: All Lock Knobs on Tube Assembly **MUST** be aligned with a detent and securely tightened in closed position (see p. 04, 21).

CAUTION: Improper placement of clamp on table rail over rail mounting bolt will cause misalignment of jaws and prevent secure attachment to table (see p. 11-12).

CAUTION: Disassemble unit prior to cleaning. The spool cap nut must be removed to separate the spool, spool cap, crank handle assembly and gearbox assembly (see page 34-37). ***It is not necessary to remove fasteners or roll pins for proper cleaning and sterilization.*** Further disassembly may void warranty

CAUTION: **Always allow rake plate to hang freely when winding Cable.** The weight of Rake Plate allows for proper alignment of Cable on Spool. Failure to allow the Rake Plate to hang freely may cause the Cable to kink during winding. Leave approximately one to two inches of Cable exposed to prevent flexing of Cable on Cable Guide at insertion site. (see p. 31, 43).

CAUTION: Always insert spool cap pin into the groove of the gearbox. Failure to do so may result in disassembly or damage to the unit (see p. 26, 30 & 43).

CAUTION: Always stabilize the single rake by hand to elevate and expose operative site. Failure to do so may result in rake slipping (see p. 07).

CAUTION: **The Dull Tip Sternal Rake Plate is available as an accessory. The exact physiology of the sternum cannot be determined until the chest is opened. Therefore, the requesting institution assumes responsibility of having a Sharp Tip Sternal Rake Plate Assembly available at all times** (see p. 06).

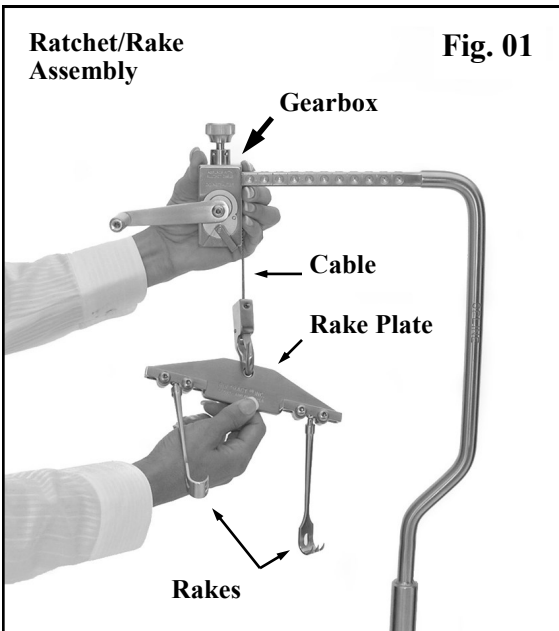

RATCHET/RAKE ASSEMBLY, 4100-IMR-6, is a unique retractor to lift an incision site. The ratchet portion of the Rultract® Retractor operates as a winch. When lifting, tension generated on the Cable is transferred to the self-locking Gearbox. The ratcheting system (Fig. 01) gently and evenly elevates the sternum at approximate increments of 1 mm. per click and locks into place. Rake Plate and Rakes pivot independently to adapt to the configuration of the sternum.

Attaching Ratchet To Top Post

Back out (open) the non-removable Lock Knob until it stops (Fig. 02). The Crank Handle may be placed either to the right or left of the surgeon depending on preference. The Top Post has alignment marks and detents on the squared section for securing the Gearbox to the post. Slide the Ratchet onto Top Post to desired position between alignment marks. Placement of the Gearbox between alignment marks locates the Lock Knob directly over detent for proper tightening (Fig. 04). Tip of Lock Knob must completely insert into detent of Top Post to assure proper seating. Note opened and closed position of Lock Knob (Fig. 05 & 06). **CAUTION: Hand tighten Lock Knob and Spool Cap Nut securely** (Fig. 02).

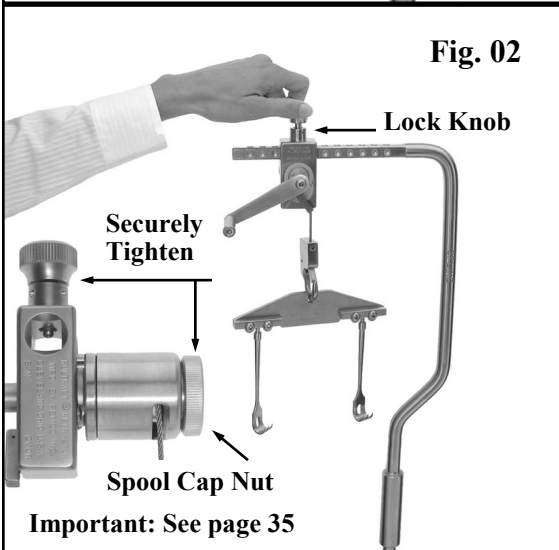

Release or Reverse Ratchet

To release or reverse the Ratchet, firmly grasp Crank Handle and turn slightly (approximately 1 mm.) in the direction it will move. While maintaining tension on the crank handle, simultaneously shift Ratchet Lever **COMPLETELY** in the opposite direction to slowly lower site (Fig. 03).

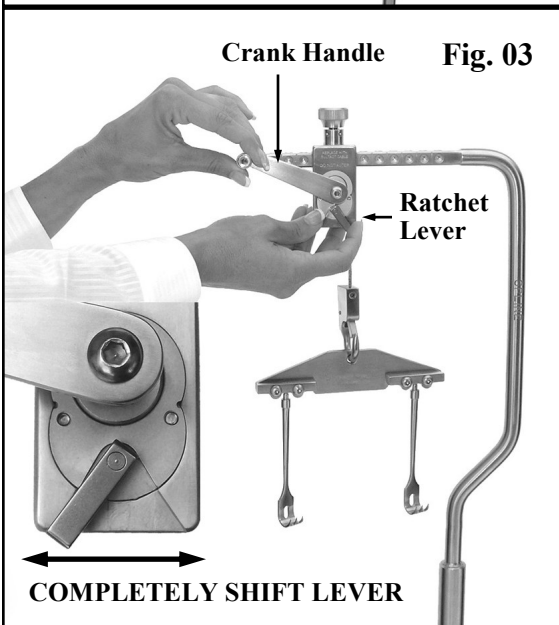

<p>Tip of Lock Knob must insert into detent of square bar</p>	<p>Knob Opened</p>	<p>Knob Closed</p>
<p>Fig. 04</p> <p>Labels: Tip, Detent, Alignment Marks</p>	<p>Fig. 05</p>	<p>Fig. 06</p>

Suggestions for Application and Removal of Rultract® Sternotomy Rakes

01. Gearbox should be positioned and secured in place at center of Top Post for average size patient.
02. Position Rakes at lower manubrium and lower sternum.
03. Place flat surface of the Rake flush against the sternal edge for secure grab.

The Ratchet mechanism will retract the operative site at approximately 1 mm. per click and lock into place after each click. Retract sternum slowly as dissection progresses medially. **Slowly elevate throughout procedure as needed for exposure. To release or reverse the ratchet, firmly grasp Crank Handle and turn slightly (approximately 1 mm.) in the direction it will move. While maintaining tension on the Crank Handle, simultaneously shift ratchet lever COMPLETELY in the opposite direction to slowly lower site.**

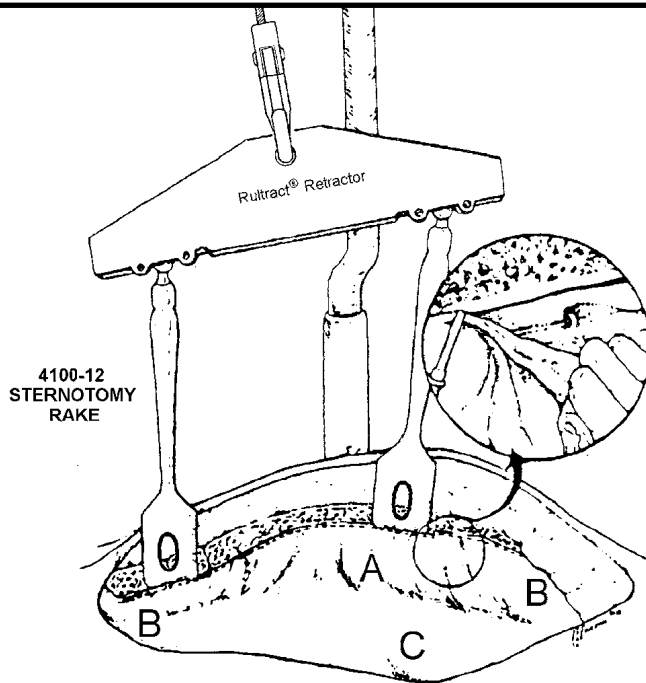

OPERATOR'S VIEW:

Operator's view after placement of the retractor.
 A) Fibrofatty areolar tissue.
 B to B) After completing incision, gentle retraction and finger dissection exposes vessels.
 C) Pericardium.

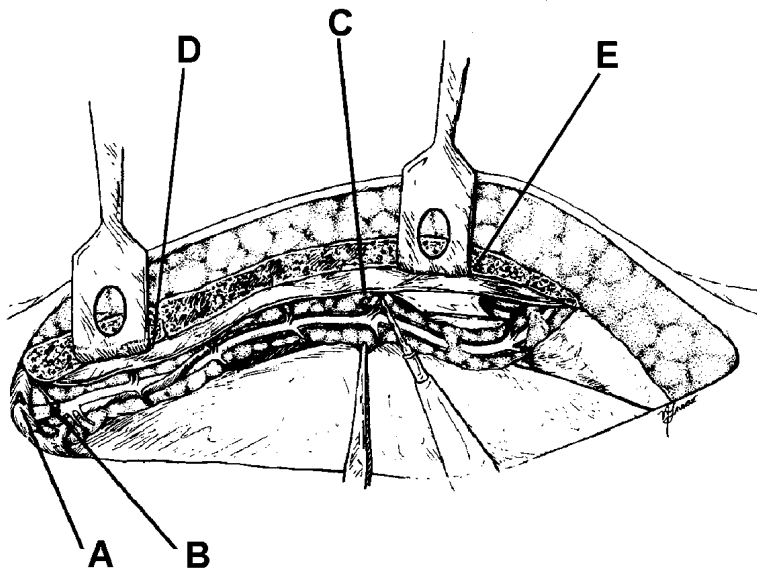

PROPER PLACEMENT:

Proper placement of rakes at lower manubrium and lower sternum. Parallel incisions 1 cm. lateral and medial to the internal thoracic vessels. Gentle retraction from the lateral edge of the pedicle helps in the dissection.
 (A) Subclavian vein.
 (B) Internal thoracic artery.
 (C) Perforating branches.
 (D) Lower manubrium.
 (E) Lower sternum.

From the Department of Thoracic and Cardiovascular Surgery,
 St. Vincent Charity Hospital and Health Center, East 22nd Street, Cleveland, OH 44115

Rultract Inc. 5663 Brecksville Rd. Cleveland, Ohio 44131 U.S.A.
 Email: rultract@rultract.com Website: www.rultract.com

ACCESSORIES:

SINGLE RAKE: Remove the supplied Sharp Tip Sternal Rake Plate Assembly from the Snap Clip (Fig. 01) and replace with a single rake. Example: With an Extender Bar and Snap Clip, the unique lifting design of the Rultract® System may be used with a variety of single rakes. The optional Extender Bar gives direct upward lift of xiphoid area (Fig. 02).

DULL TIP RAKE PLATE: The Dull Tip Sternal Rake Plate Assembly is an accessory available for use with the fragile sternum. *Use of the Dull Tip Rake Plate is at surgeon's discretion.* (See *Proper Placement* drawing, p. 5).

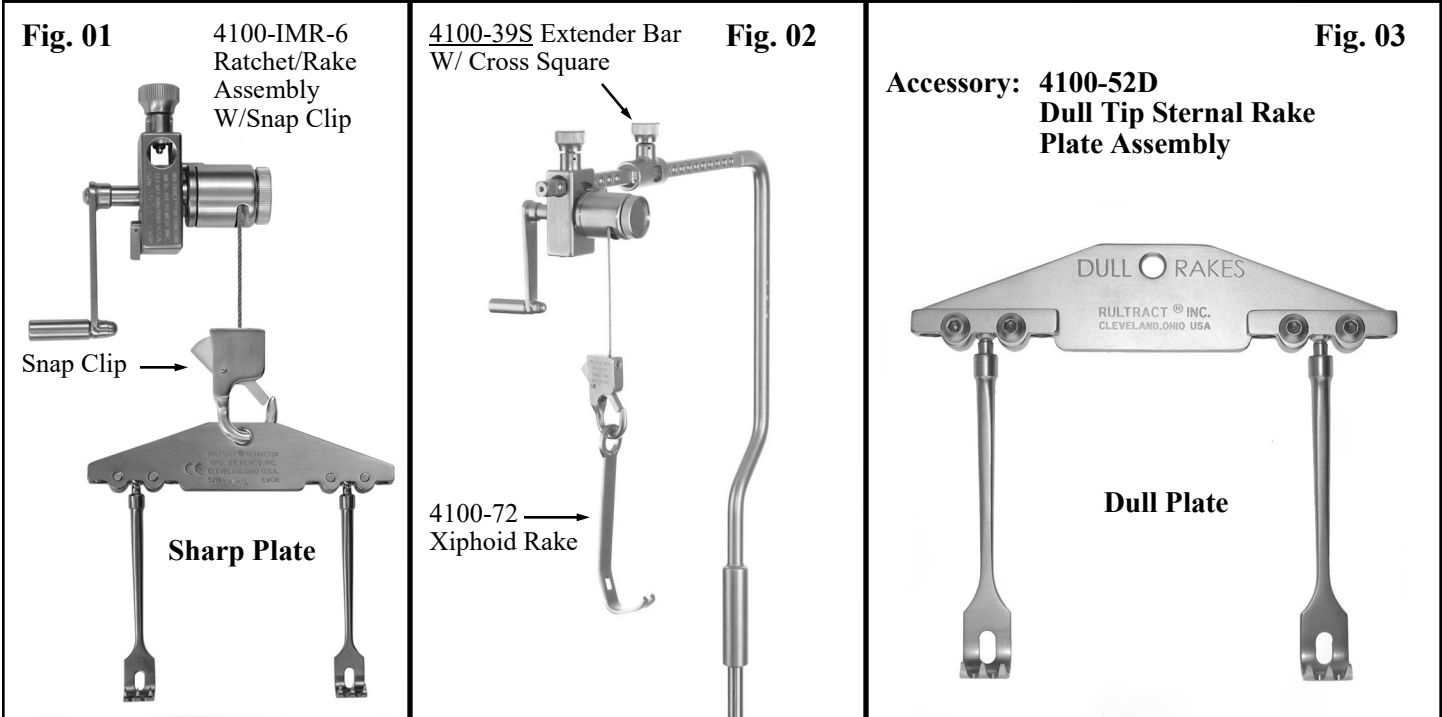

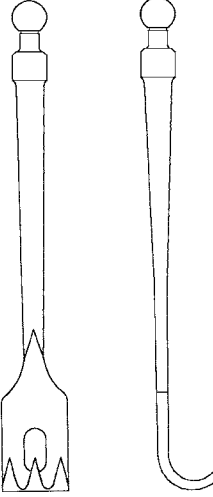
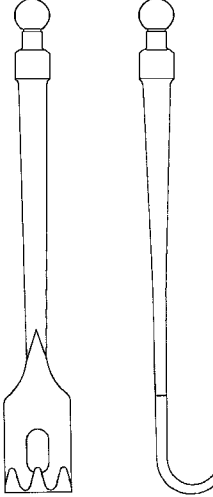
Comparison: Sharp Tip Rake vs. Dull Tip Rake	Sharp Tip Sternal Rake 4100-12	Dull Tip Sternal Rake 4100-12D
<p><u>Each Ratchet/Rake Assembly is sold with Sharp Tip Sternal Rakes.</u></p> <p>The <u>supplied</u> Sharp Tip Sternal Rakes on the Rultract® IMA retractor are designed for use on all patients. To secure elevation of the sternum without slipping the flat surface of rake should be flush against sternal edge. While retracting slowly, the rake tips penetrate the sternum.</p> <p><u>CAUTION:</u> The Dull Tip Sternal Rake Plate is available as an accessory. The exact physiology of the sternum cannot be determined until the chest is opened. Therefore, the requesting institution assumes responsibility of having a Sharp Tip Sternal Rake Plate Assembly available at all times.</p>		

Single Rake Use: Xiphoid Entry

Attach Extender Bar to end of Top Post and mount Ratchet Assembly. Remove Sternal Rake Plate Assembly from Snap Clip and replace with Xiphoid Rake (Fig. 01).

After dissection is started position rake under xiphoid process (Fig. 02). Stabilize rake by hand (Fig. 03). **SLOWLY** elevate to insure proper placement. The ratchet mechanism will retract the operative site at approximately 1 mm. per click and lock into place after each click. ***Slowly elevate throughout the procedure as needed for exposure.***

Caution: Always stabilize the single rake by hand to elevate and expose operative site. Failure to do so may result in rake slipping.

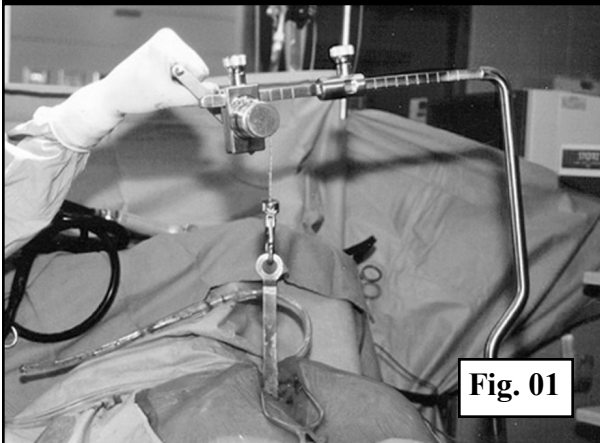

Fig. 01

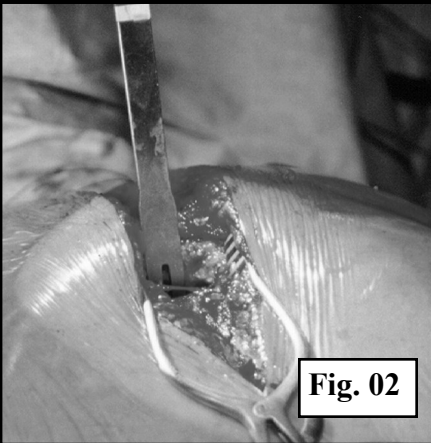

Fig. 02

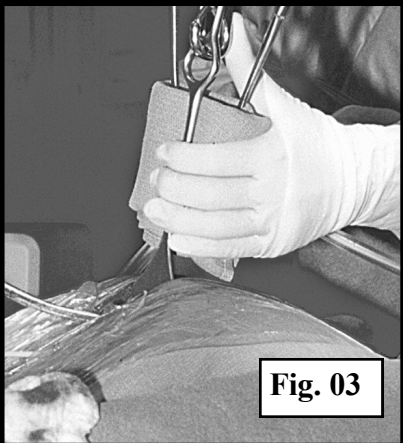

Fig. 03

4100-39S: EXTENDER BAR with CROSS SQUARE (see p. 21)

Horizontal Position Into Hub: Extender Bar attached to Top Post positions ratchet over xiphoid area for direct upward lift of incision site (Fig. 04).

Horizontal Position Thru Cross Square for Right Angle Extension:

With arm board in place Cross Square feature provides proper placement of ratchet to chest wall by mounting Rultract® System above or below the arm board (Fig. 05 & 06).

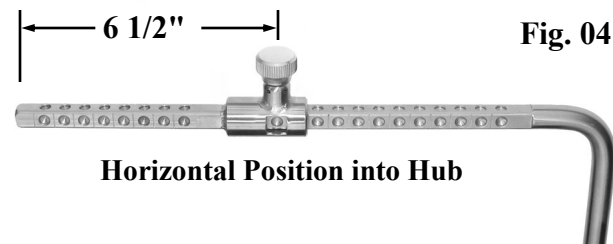

Fig. 04

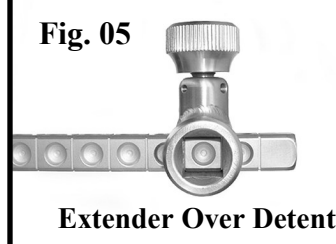

Fig. 05

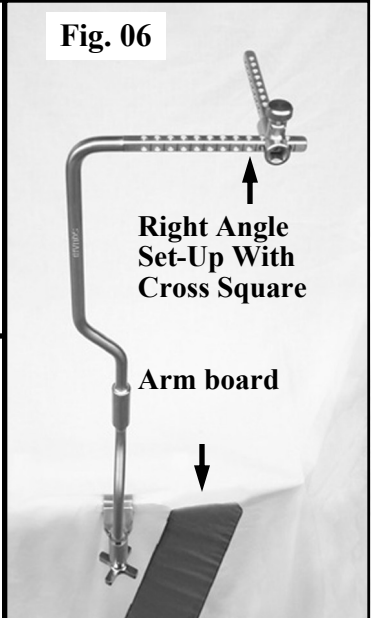
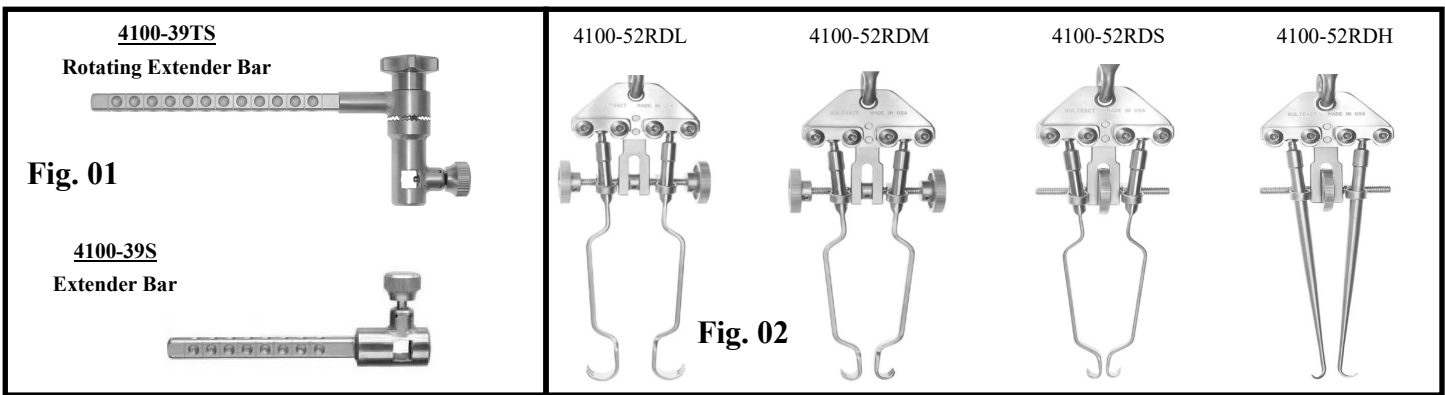

Fig. 06



Resternotomy Attachments

Attach Extender Bar of choice (Fig. 01) to end of Top Post (see pages 20-22 for detailed instructions). Attach the Ratchet Assembly at the desired location on the Extender bar. Connect desired size Resternotomy depending on patients anatomy and surgeons preference. (Fig. 02).

Technique and procedure:

The old sternotomy incision is reopened from the skin down to the sternum. The scar is not excised unless it is unusually wide. Exposed sternal wires or other closure material are then removed.

The linea alba below the xiphoid process is reopened. Finger dissection under the xiphoid and lower sternum is to be avoided, as the right ventricle can easily be injured with this maneuver. While the edges of the linea alba are separated with the assistance of hand held retractors, division of the outer table of the sternum is begun.

Once the lowest part of the sternum is completely divided, the Rultract re-sternotomy retractor is placed at the base of the sternum to provide for ventral and cephalic traction in order to facilitate the separation of the sternal edges beginning at the lowest part of the sternum. A self-retaining Weitlaner style retractor is then placed at the base of the incision to assist in retraction.

The sternum is then spread and lifted using the Rultract re-sternotomy retractor. The gentle and precise action of the thumb wheels on the Rultract re-sternotomy retractor allows for avoidance of sudden wide retraction of the sternal edges to prevent tearing of soft tissues, such as the right atrium and ventricle, underneath the sternum.

The gentle upward and outward retraction also allows for the division of adhesions between the sternum and mediastinal structures under significantly increased direct or video assisted visualization. The retractor can be easily repositioned to provide continuous improved visualization as the dissection moves cranially until the suprasternal notch is reached. (Progressive division of the sternum can be helpful to proceed in points like the manubrium level where adhesions are usually thicker). Additional sternal wires or other closure material are then removed and the sternum is divided using a reciprocating saw.

Once the mediastinal structures are freed from adhesions and the sternum is reopened with the reciprocating saw, the Rultract re-sternotomy retractor can be removed and regular retractors are placed. From this point, the planned intracardiac procedure is performed.

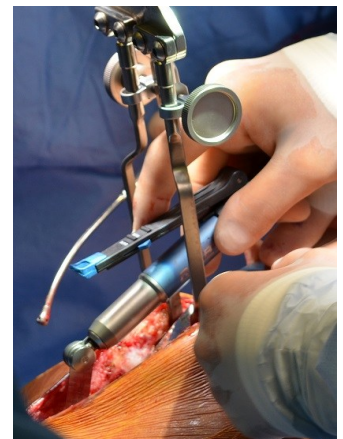
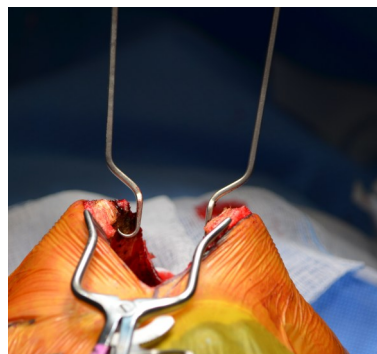

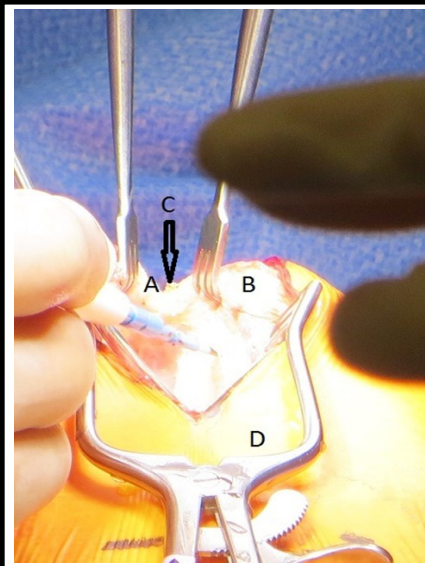

Fig. 03

- A) Right aspect of the costal margin.
- B) Left aspect of the costal margin.
- C) Base of the Sternum.
- D) Weitlaner style retractor

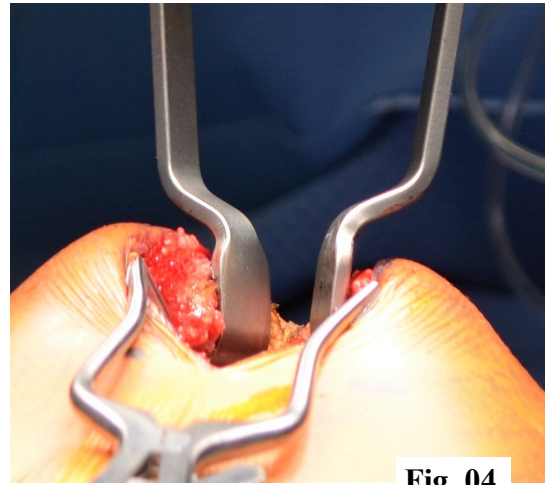

Fig. 04

Suggestions for Application and Removal of Rultract® Re-Sternotomy Rakes

1. Place the Rultract bedrail clamp at nipple height or higher.
2. Gearbox should be positioned and secured in place at center of Extender Bar for average size patient.
3. Divide upper linea alba and dissect tissue to safely position rakes on right and left aspects of the costal margin. A Weitlaner style retractor is placed below the xiphoid process to increase working area space (Fig. 3).
4. Place flat surface of the Rake flush against the costal margin for secure grab (Fig. 4).
5. Turn the handle of the Ratchet mechanism to elevate the operative site at approximately 1 mm per click. The handle will lock into place after each click and once the desired amount of elevation has been achieved.
5. Turning the rotating knobs on the Resternotomy attachments will spread the sternum slowly as dissection progresses (Fig. 5).
6. Slowly elevate and spread throughout procedure as needed for exposure.
7. Once the mediastinal structures are freed from adhesions and the sternum is reopened with the reciprocating saw, the Rultract re-sternotomy retractor can be removed and regular retractors are placed.

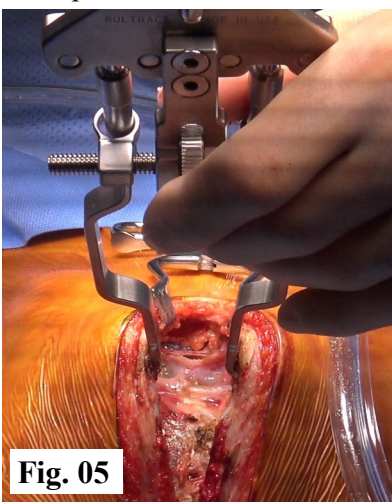
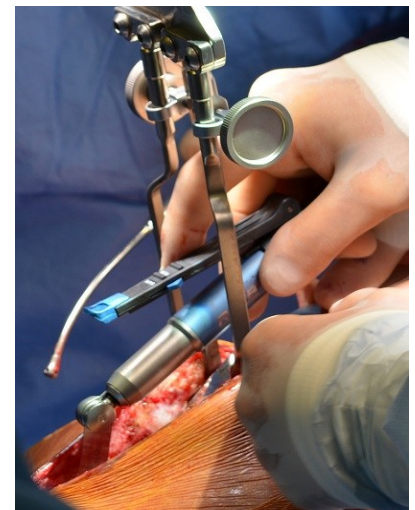

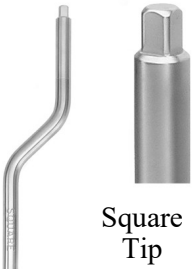

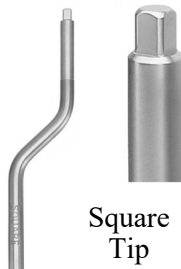







Fig. 05

8. To release or reverse the ratchet, firmly grasp Crank Handle and turn slightly (approximately 1 mm) in the direction it will move. While maintaining tension on the Crank Handle, simultaneously shift ratchet lever COMPLETELY in the opposite direction to slowly lower site.

Slowly elevate throughout the procedure as needed for exposure.

Caution: Always stabilize the retractor by hand to elevate and expose operative site. Failure to do so may result in rake(s) slipping.



<u>POST CLAMPS</u>				SQUARE TIP 90° Angle	SPLINE TIP 18° Increments
4150	Square Tip, Double Bend Post/Clamp, Scrub Applied - 19" long				
4150S-02	Spline Tip, Single Bend Post/Clamp Scrub Applied - 19" long				
4160	Square Tip, Double Bend Post/Clamp, Circulator Applied - 20" long				
4160S-02	Spline Tip, Single Bend Post/Clamp, Circulator Applied - 20" long				
					
Square Tip	Spline Tip	Square Tip	Spline Tip	<p><u>Cleaning: Clamp</u></p> <ul style="list-style-type: none"> • Do not disassemble for cleaning. • <u>Do not remove retaining screw (s).</u>** • Do not open or close handle (s) completely. • Jaws should be partially opened. • Jaws and handles should have free movement. 	
					
4150 Scrub Applied	4150S-02 Scrub Applied	4160 Circulator Applied	4160S-02 Circulator Applied		

<p><u>CLAMPS: COMBINATION CLAMP WITH REMOVEABLE POST</u></p> <p>4110 Round Base Combination Clamp 4110S Square Base Combination Clamp</p>	<p><u>NOTE:</u> The difference in appearance and function of the 4110 Clamp is the internal <u>round base</u> or <u>square base</u>. See Below.</p>
--	--

4110 Round Base	4110S Square Base
------------------------	--------------------------

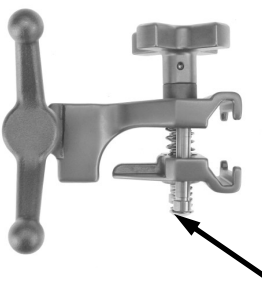
 <p><u>Round Base</u></p>	 <p><u>Square Base</u></p>
<p><u>WARNING:</u> Removal of <u>retaining screw(s)</u> **(4110P-12) will cause device to come apart. This will result in failure during use.</p>	
<p><u>**Retaining Screw locations</u></p>	
<p><u>DO NOT REMOVE RETAINING SCREWS</u></p>	

FUNCTION OF CLAMP JAW

1. Each table clamp attaches to the operating table in a similar manner.
2. The patented shape of the jaw allows the clamp to attach to different size rails, with or without a drape.
3. Each clamp has a handle assembly, which is used to tighten (close) or loosen (open) the clamp jaws. Turning the handle clockwise tightens jaws. Turning the handle counter clockwise loosens jaws.
Note: The combination clamp may be inverted. The locking rotation is still clockwise, though it may appear to be counter clockwise (Fig. 06).
4. Most operating tables have rail mounting bolts which attach the rail to the table. The clamp jaws have a centrally located notch to allow for positioning over a rail mounting bolt (Fig. 01 and 02).

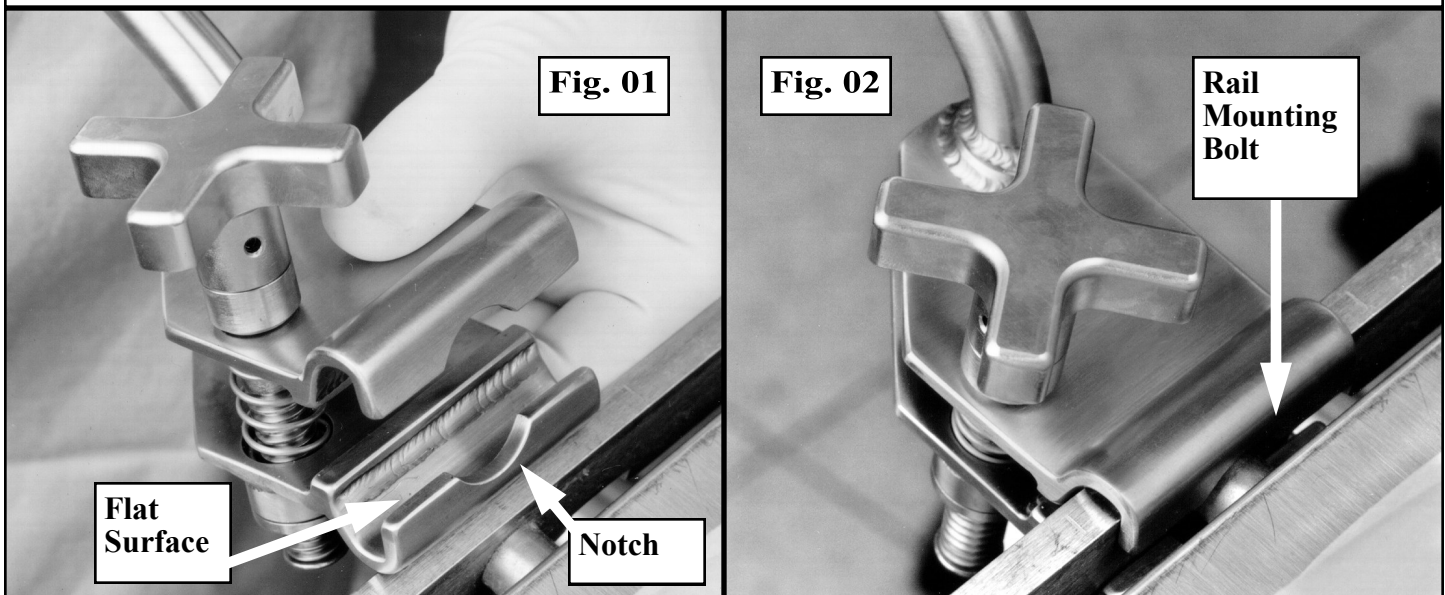

ATTACHING FIXED POST/CLAMP and COMBINATION CLAMP TO OPERATING TABLE



For Midsternotomy: Attach clamp to table rail approximately two inches below patient's axilla on the side to be dissected. Clamp position may change or be adjusted according to age and size of patient or physician's technique or preference.

1. Open clamp jaws completely by turning the cross handle counter clockwise. Hold clamp jaws with one hand and post with the other. Check for free movement of jaws by squeezing together then releasing.
2. Before attaching clamp to table rail, check for possible obstruction.
3. Hold clamp by the upper and lower jaws with one hand and slightly tilt upper jaw inward (toward table). Place upper jaw over the rail, then pivot lower jaw inward (toward the table). Both jaws should be in line with table rail.
4. Squeeze jaws together to assure there is no obstruction between jaws and rail. While holding jaws closed, securely tighten with cross handle (Fig. 03, 04, & 05).
5. When pulling on the post or body of the clamp, there should be no movement when applied properly. If clamp has movement, check for obstruction between jaws and table rail.

REMOVE SYSTEM FROM TABLE

1. After rake (s) are removed from patient, wind cable upward leaving approximately two inches exposed.
2. Remove all accessories from top post.
3. Remove top post from post/clamp.
4. Place one hand around clamp jaws to hold together during removal. Loosen cross handle by turning counter-clockwise until handle stops. A slight wiggle of clamp will release the clamping pressure which allows spring loaded jaws to separate.

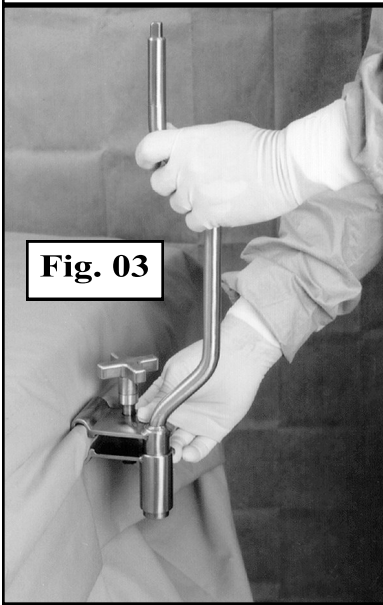
Demonstration: Attaching Clamp to rail

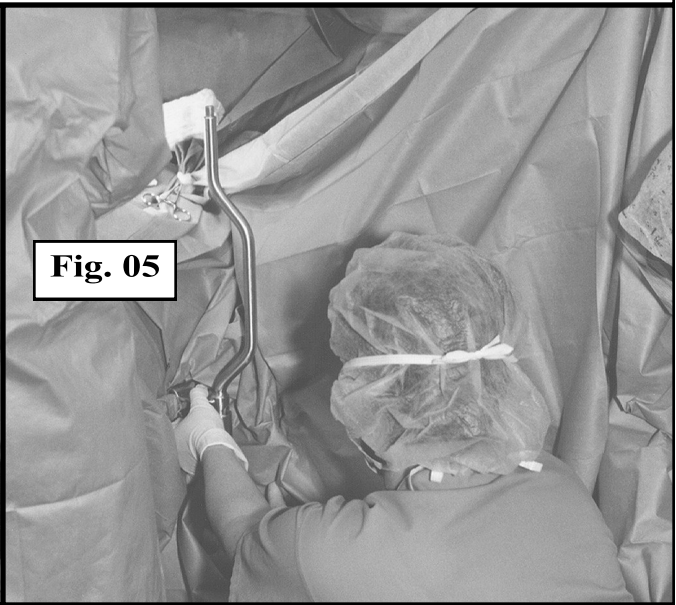
 <p>Fig. 03</p>	 <p>Fig. 04</p>	 <p>Fig. 05</p>
<p>Scrub Applied 4150 or 4150S-02</p>	<p>Circulator Applied 4160 or 4160S-02</p>	<p>Demonstration: Attaching Clamp to rail over drape.</p>

Note: If Clamp still has movement after tightening

1. Check for obstruction (s) around the jaws. (Rail spacers bolts, padding, drapes, arterial lines, etc.) It may also be caused by jaw (s) of the clamp being out of alignment. This prevents full contact of clamp jaw on the table rail.
2. Clamp may appear to have some movement but is tight on the table rail. This movement may be caused by a loose table rail mounting. To remedy this, either have the bed rail tightened or return the Post/Clamp to Rultract® for re-alignment.
3. The original Post/Clamps do not have notches along flat surface of jaw. Notches will be added when returned for factory service (Fig. 01).

Combination Clamp Fig. 06

4110 or 4110S
Scrub Applied

4110 or 4110S
Circulator Applied
(Inverted)



Wing Handle: For proper locking, post must be inserted flush with bottom of clamp or lower. Turn wing handle clockwise to tighten securely. This will compress the clamp body around the post.

Combination Clamp Features: (Fig. 06)

1. The Combination Clamp can be applied by scrub or circulator.
2. The Combination Clamp can be attached directly to the table rail or over the drape.

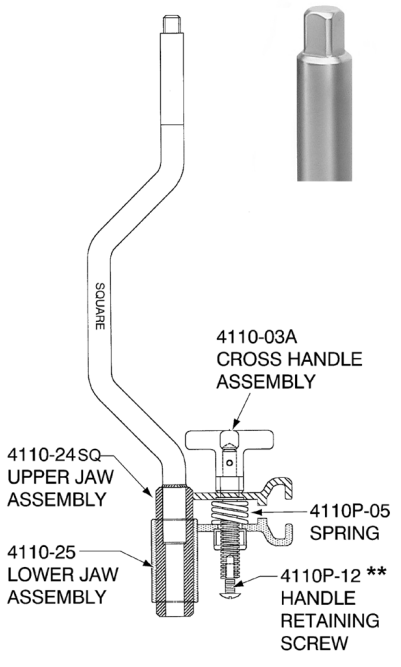
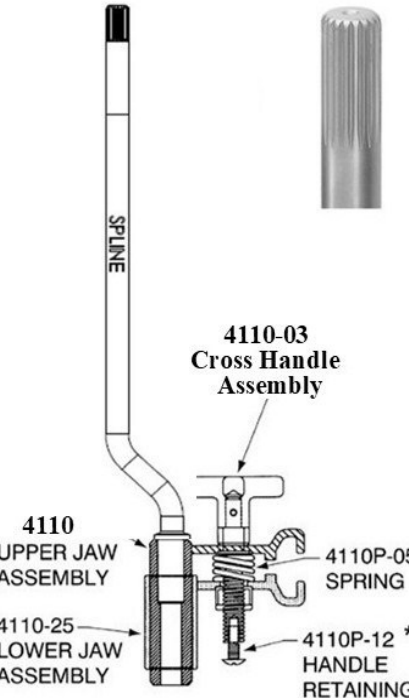
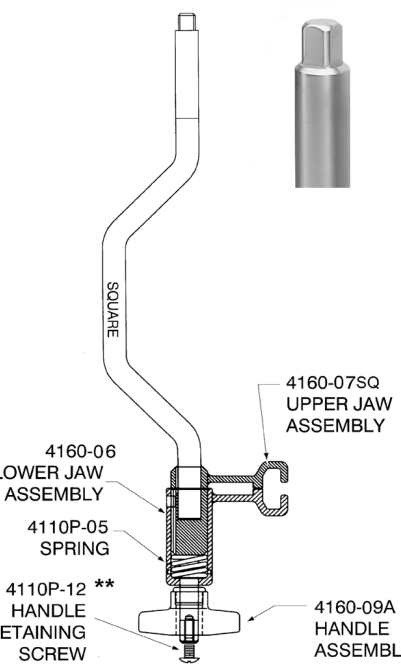
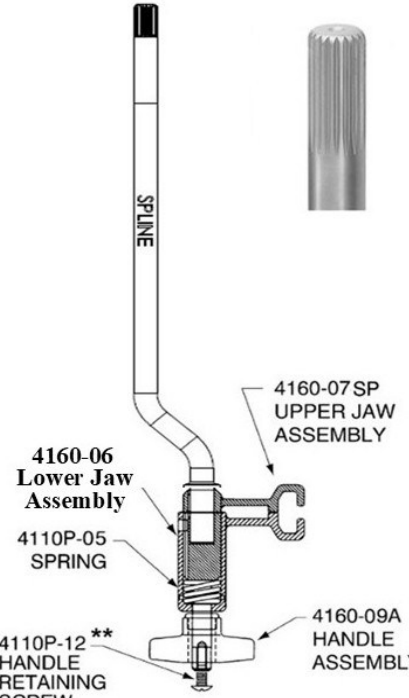
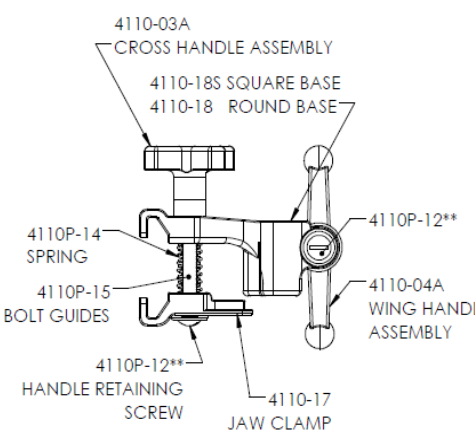
<p>4150 Square Tip Double Bend Post/Clamp (scrub applied)</p>	<p>4150S-02 Spline Tip Single Bend Post/Clamp (scrub applied)</p>	<p>CLAMP SPECIFICATIONS:</p>
 <p>4110-03A CROSS HANDLE ASSEMBLY</p> <p>4110-24SQ UPPER JAW ASSEMBLY</p> <p>4110-25 LOWER JAW ASSEMBLY</p> <p>4110P-05 SPRING</p> <p>4110P-12 ** HANDLE RETAINING SCREW</p>	 <p>4110-03 Cross Handle Assembly</p> <p>4110 UPPER JAW ASSEMBLY</p> <p>4110-25 LOWER JAW ASSEMBLY</p> <p>4110P-05 SPRING</p> <p>4110P-12 ** HANDLE RETAINING SCREW</p>	<p>CAUTION:</p> <p>Improper placement of clamp on table rail over rail mounting bolt will cause misalignment of jaws and prevent secure attachment to table (see page 11).</p> <p>WARNING:</p> <p>Removal of <u>retaining screw (s)</u> ** (4110P-12) will cause device to come apart. This will result in failure during use.</p> <p><u>DO NOT REMOVE RETAINING SCREWS</u></p>
<p>4160 Square Tip Double Bend Post / Clamp (circulator applied)</p>	<p>4160S-02 Spline Tip Single Bend Post/Clamp (circulator applied)</p>	<p>4110 and 4110S Combination Clamp</p>
 <p>4160-07SQ UPPER JAW ASSEMBLY</p> <p>4160-06 LOWER JAW ASSEMBLY</p> <p>4110P-05 SPRING</p> <p>4110P-12 ** HANDLE RETAINING SCREW</p> <p>4160-09A HANDLE ASSEMBLY</p>	 <p>4160-07SP UPPER JAW ASSEMBLY</p> <p>4160-06 Lower Jaw Assembly</p> <p>4110P-05 SPRING</p> <p>4110P-12 ** HANDLE RETAINING SCREW</p> <p>4160-09A HANDLE ASSEMBLY</p>	 <p>4110-03A CROSS HANDLE ASSEMBLY</p> <p>4110-18S SQUARE BASE</p> <p>4110-18 ROUND BASE</p> <p>4110P-14 SPRING</p> <p>4110P-15 BOLT GUIDES</p> <p>4110P-12** HANDLE RETAINING SCREW</p> <p>4110-04A WING HANDLE ASSEMBLY</p> <p>4110-17 JAW CLAMP</p> <p><u>DO NOT REMOVE RETAINING SCREWS</u></p>

Rultract Inc. 5663 Brecksville Rd. Cleveland, Ohio 44131 U.S.A.
 Email: rultract@rultract.com Website: www.rultract.com

TOP POSTS: Square and Spline inserts

4100-32A	Square Top Post - standard length -	9 1/2" x 18" long (square insert)
4100-32AL	Square Top Post - extended length -	9 1/2" x 22" long (square insert)
4100-32AS-02	Spline Top Post, Single Bend - standard length	9 1/2" x 19" long (spline insert)
4100-32ALS	Spline Top Post - extended length -	9 1/2" x 23" long (spline insert)

THIS ITEM HAS BEEN DISCONTINUED BY THE MANUFACTURER

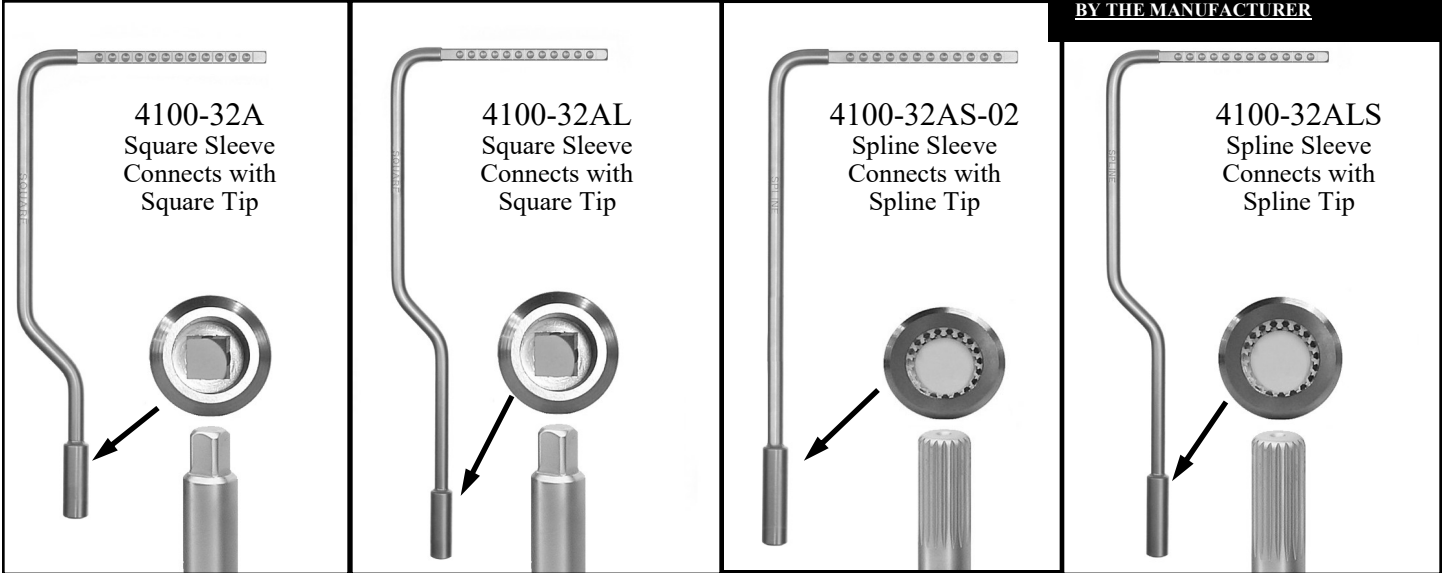

ONE PIECE POSTS: Round Base

4100-08	One piece post - 9 1/2" x 30" long
---------	------------------------------------

THIS ITEM HAS BEEN DISCONTINUED BY THE MANUFACTURER

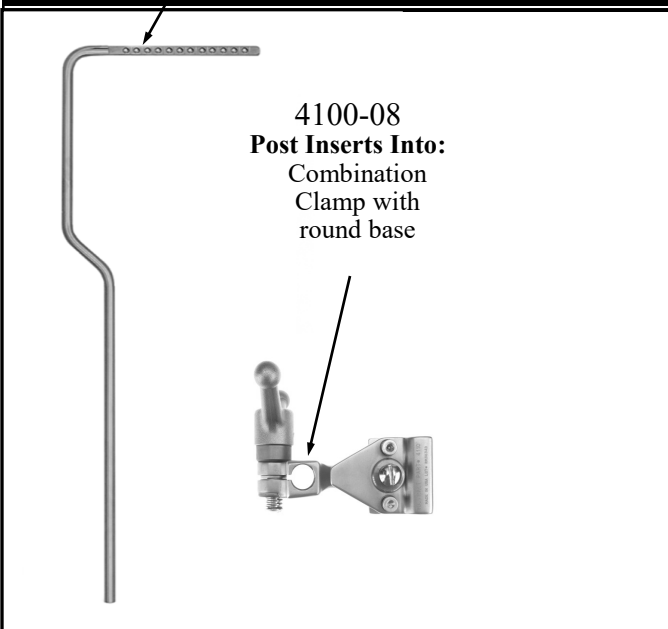

TILTING TOP POSTS: Square and Spline inserts

4100-32AT	Square Tilting Top Post - 12 1/2" x 20" long
4100-32AST	Spline Tilting Top Post - 12 1/2" x 21" long

THESE ITEMS HAVE BEEN DISCONTINUED BY THE MANUFACTURER

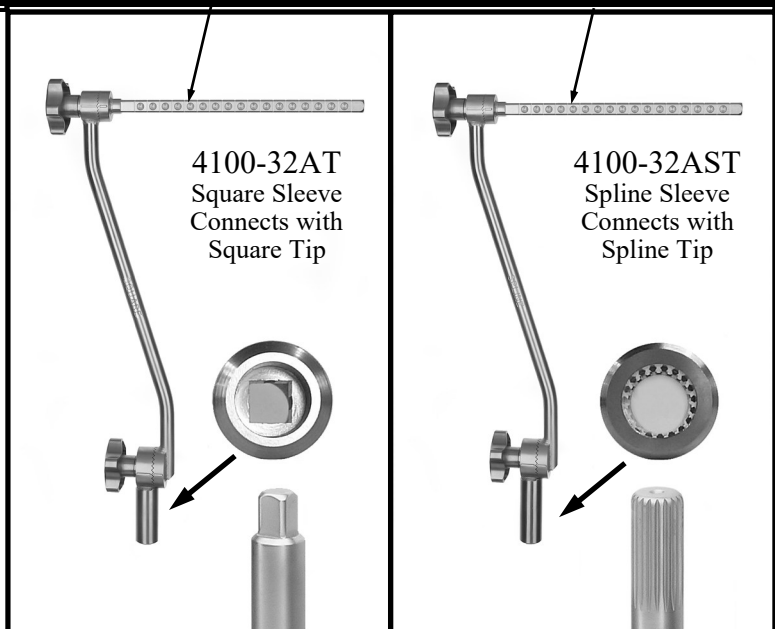

SQUARE TOP POSTS: 4100-32A and 4100-32AL

A square insert top post can only be used with a square tip post/clamp or bottom post. Once the post/clamp or bottom post has been securely fastened to the operating table, hold the top post vertically with the top perpendicular to the operating table. Place the sleeved end of the top post over the square tip of the connecting post and allow the top post to slide downward until the squares mate. A slight rotation of the top post may be needed to achieve proper seating. The squared post system angles at 90 degree increments. To change position of the top post, grasp the sleeve and the squared top end near the bend. Lifting upward approximately one inch will disengage the squared sections and allow the top post to angle in either direction to a 90 degree position. To reconnect squared sections, lower top post until it stops. A slight rotation of the top post may be needed to achieve proper seating. When the top post is properly seated it will not rotate.



SQUARE SET: ALLOWS TOP POST TO ANGLE AT 90 DEGREE INCREMENTS

INTERNAL SQUARE

SQUARE TIP

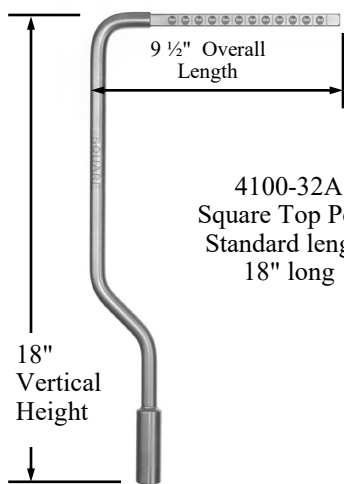
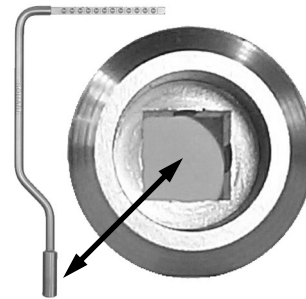

4100-32A
Square Top Post,
Standard length
18" long

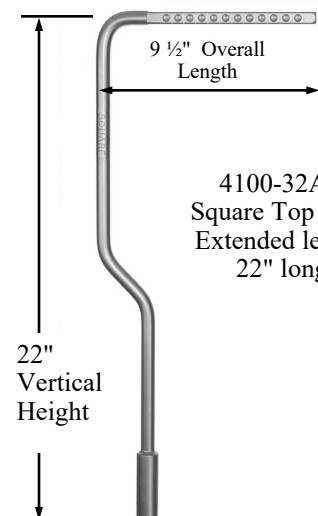

4100-32AL
Square Top Post,
Extended length
22" long

Square Top Post Connects to: Options

Description: Post/Clamps and Bottom Posts

- 4150 Square Tip, Double Bend Post/Clamp, Scrub Applied
- 4160 Square Tip, Double Bend Post/Clamp, Circulator Applied
- 4100-28C Square Tip Double Bend Bottom Post, (square base)
- 4100-28CP Offset Square Tip Bottom Post, (square base).
- 4100-32C Square Tip Bottom Post with collar, (round base).

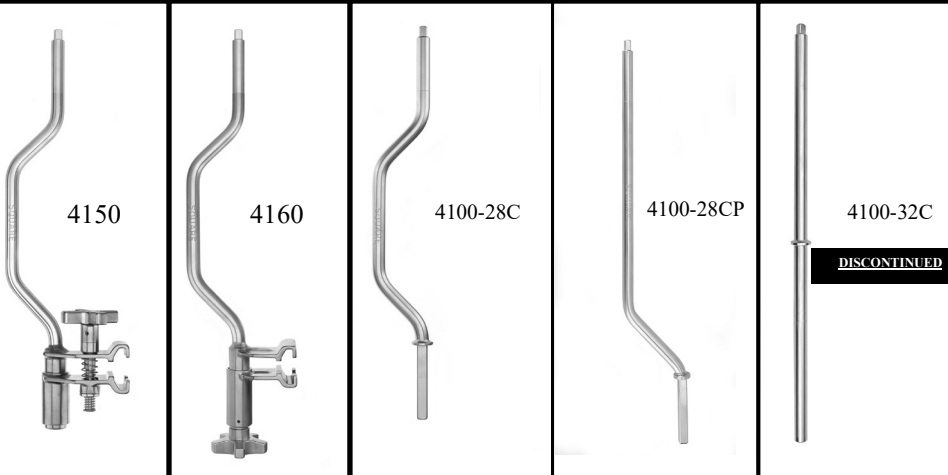

SPLINE TOP POST: 4100-32AS-02 and 4100-32ALS

A spline insert top post can only be used with a spline tip post/clamp or bottom post. Once the post/clamp or bottom post has been securely fastened to the operating table, hold the top post vertically with the top perpendicular to the operating table. Place the sleeved end of the top post over the spline tip of the connecting post and allow the top post to slide downward until the splines mate. A slight rotation of the top post may be needed to achieve proper seating. The spline post system angles at 18 degree increments. To change position of the top post, grasp the sleeve and the squared top end near the bend. Lifting upward approximately one inch will disengage the spline sections and allow the top post to angle in either direction at 18 degree increments. To reconnect spline sections lower top post until it stops. A slight rotation of the top post may be needed to achieve proper seating. When the top post is properly seated it will not rotate.



THIS ITEM HAS BEEN DISCONTINUED BY THE MANUFACTURER

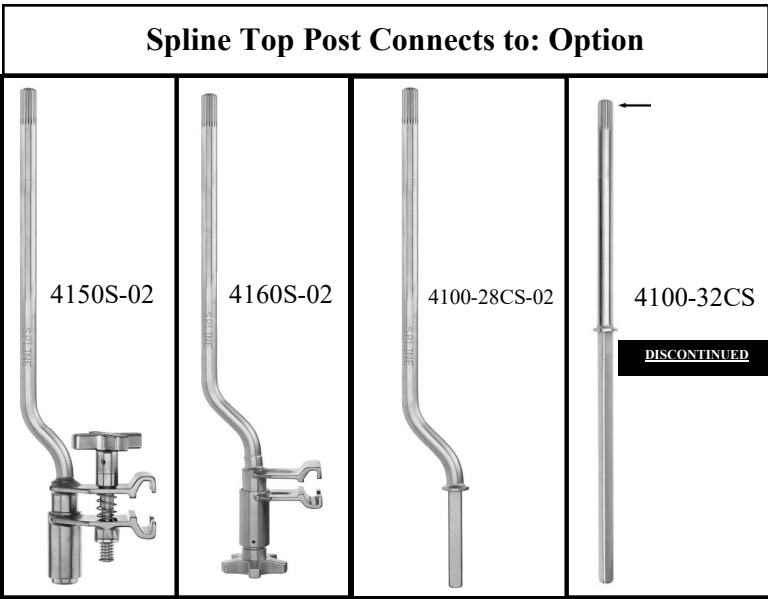
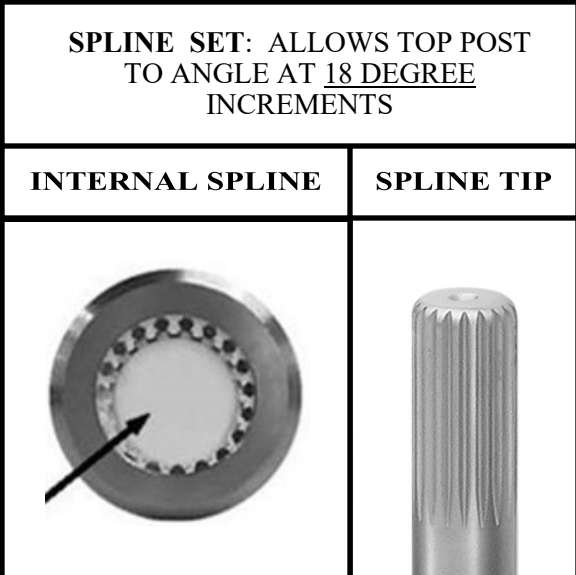
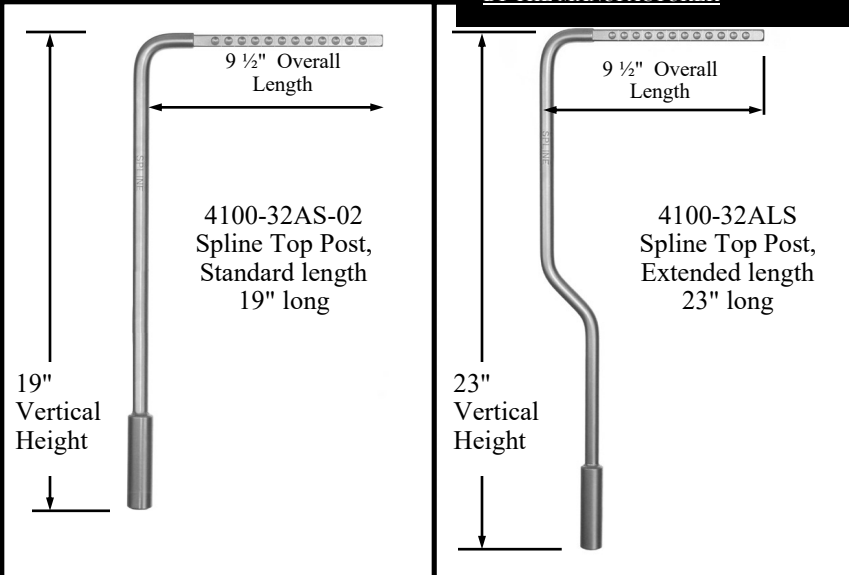

Description: Post/Clamps and Bottom Posts

- 4150S-02 Spline Tip, Single Bend Post/Clamp Scrub Applied.
- 4160S-02 Spline Tip, Single Bend Post/Clamp Circulator Applied.
- 4100-28CS-02 Spline Tip Single Bend Bottom Post, (square base).
- 4100-32CS Spline Tip Bottom Post with collar, (square base).

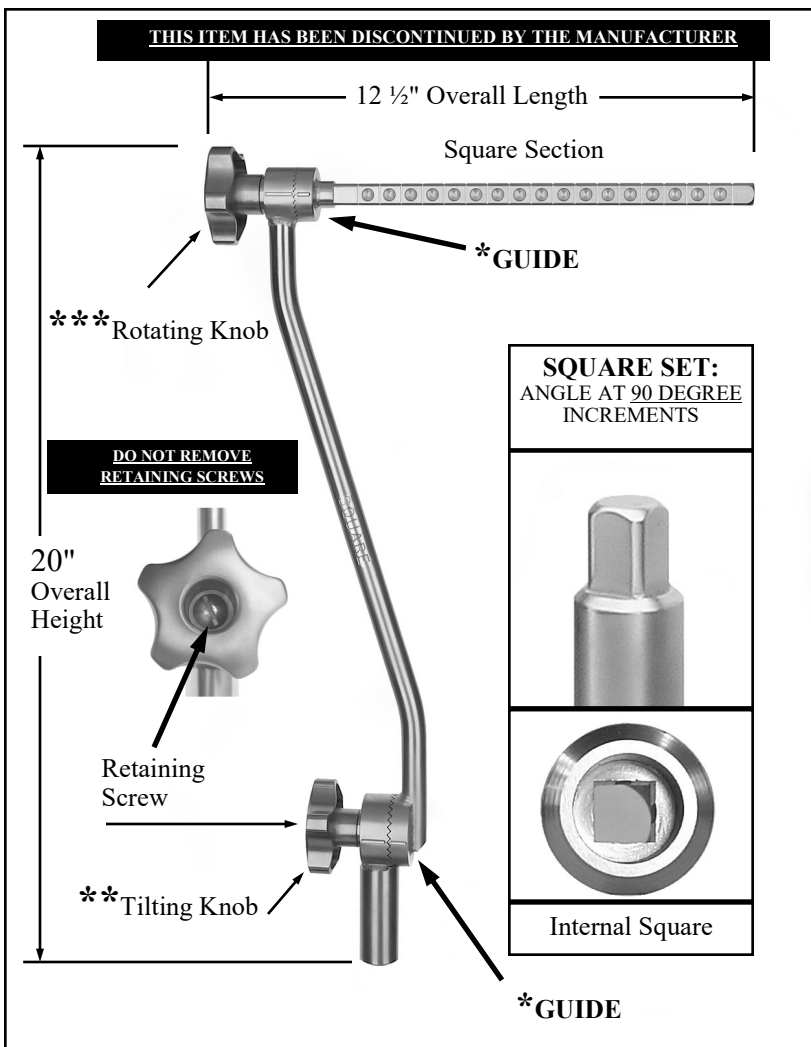

SQUARE TILTING TOP POST: 4100-32AT

A square insert top post can only be used with a square tip post/clamp or bottom post. Once the post/clamp or bottom post has been securely fastened to the operating table, hold the top post vertically with the top perpendicular to the operating table. Place the sleeved end of the top post over the square tip of connecting post and allow the top post to slide downward until the squared sections mate. A slight rotation of the top post may be needed to achieve proper seating. The squared post system angles at 90 degree increments. To change position of the top post, grasp the sleeve and the squared top near the bend. Lifting upward approximately one inch will disengage the squared sections and allows the top post to angle in either direction at 90 degrees. To reconnect squared sections, lower top post until it stops. A slight rotation of the top post may be needed to achieve proper seating. When the top post is properly seated it will not rotate.

Guide Marks:

To obtain true vertical position, guide* marks on both upper and lower sections of post must be aligned.

Tilt Post:

Top post properly seated can now be tilted to the desired position. While holding the squared top section, **loosen the attached tilting knob**** counter clockwise **until it stops**. This will separate the spring loaded sections which allows the post to tilt. When the desired position is obtained, tighten the knob by turning clockwise. This function allows for various height and lateral retraction.

Rotate Square Section:

The square top section rotates 360 degrees. To rotate, **loosen the attached rotating knob***** by turning counter clockwise **until it stops**. The toothed sections are spring loaded to help separate the two halves. Once separated the squared top section can be rotated freely. When the desired position is obtained, tighten the rotating knob by turning clockwise. When tightened, the teeth mate and the unit is secure. This function allows the user to adjust the lift angle to a lateral position between the ratchet and the incision site.

Square Tilting Top Post Connects to: Options

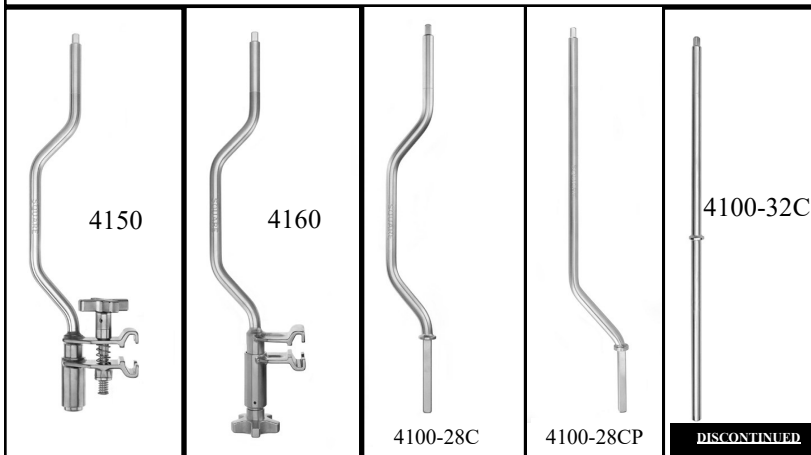

- 4150 Square Tip, Double Bend Post/Clamp, Scrub Applied.
- 4160 Square Tip, Double Bend Post/Clamp, Circulator Applied.
- 4100-28C Square Tip Double Bend Bottom Post (square base).
- 4100-28CP Square Tip Offset Bottom Post (square base).
- 4100-32C Square Tip Bottom Post w/ collar (round base).

Cleaning:

- Do not disassemble Tilting Post for cleaning.
- Do not remove retaining screws.
- Do not open or close knobs completely.
- Loosen knobs for partial separation.
- Sections and knobs should have free movement.

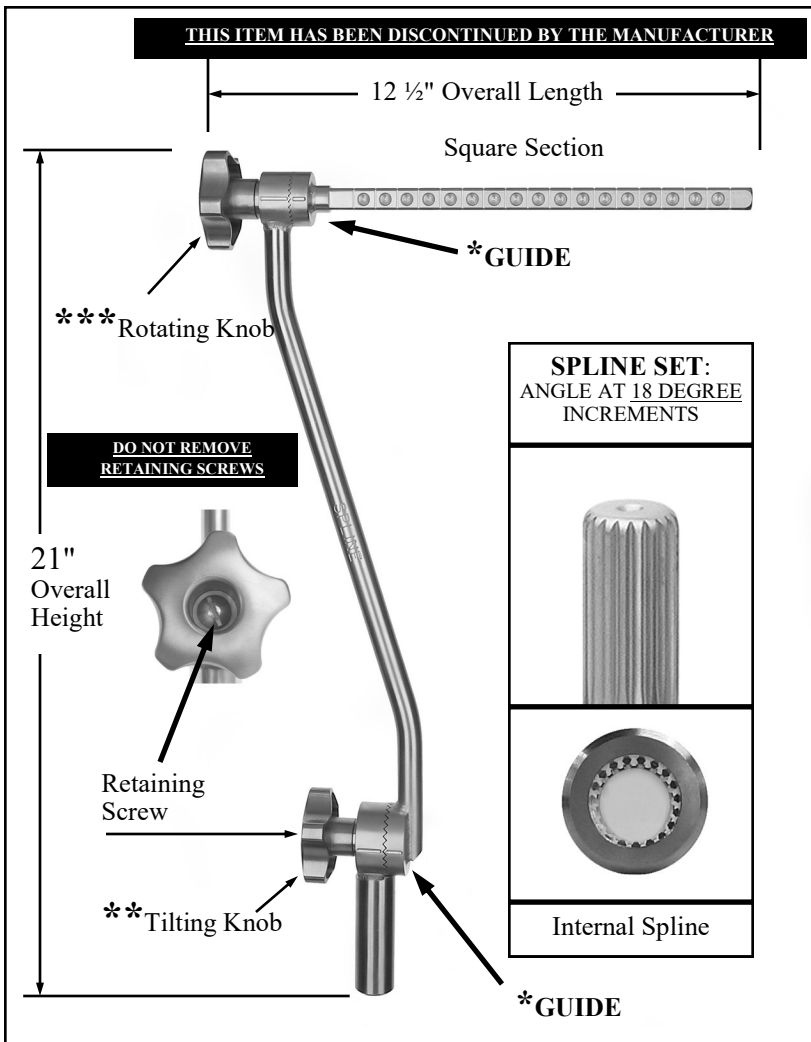

SPLINE TILTING TOP POST: 4100-32AST

A spline insert top post can only be used with a spline tip post/clamp or bottom post. Once the post/clamp or bottom post has been securely fastened to the operating table, hold the top post vertically with the top perpendicular to the operating table. Place the sleeved end of the top post over the spline tip of connecting post and allow the top post to slide downward until the spline sections mate. A slight rotation of the top post may be needed for proper seating. The spline post system angles at 18 degree increments. To change position of the top post, grasp the sleeve and the squared top section near the bend. Lifting upward approximately one inch will disengage the spline sections and allows the top post to angle in either direction at 18 degree increments. To reconnect spline sections lower top post until it stops. A slight rotation of the top post may be needed to achieve proper seating. When the top post is properly seated it will not rotate.

Guide Marks:

To obtain true vertical position, guide* marks on both upper and lower sections of post must be aligned.

Tilt Post:

Top post properly seated can now be tilted to the desired position. While holding the squared top section, **loosen the attached tilting knob**** counter clockwise **until it stops**. This will separate the spring loaded sections which allows the post to tilt. When the desired position is obtained, tighten the knob by turning clockwise. This function allows for various height and lateral retraction.

Rotate Square Section:

The square top section rotates 360 degrees. To rotate, **loosen the attached rotating knob***** by turning counter clockwise **until it stops**. The toothed sections are spring loaded to help separate the two halves. Once separated the squared top section can be rotated freely. When the desired position is obtained, tighten the rotating knob by turning clockwise. When tightened, the teeth mate and the unit is secure. This function allows the user to adjust the lift angle to a lateral position between the ratchet and the incision site.

Spline Top Post Connects to: Option

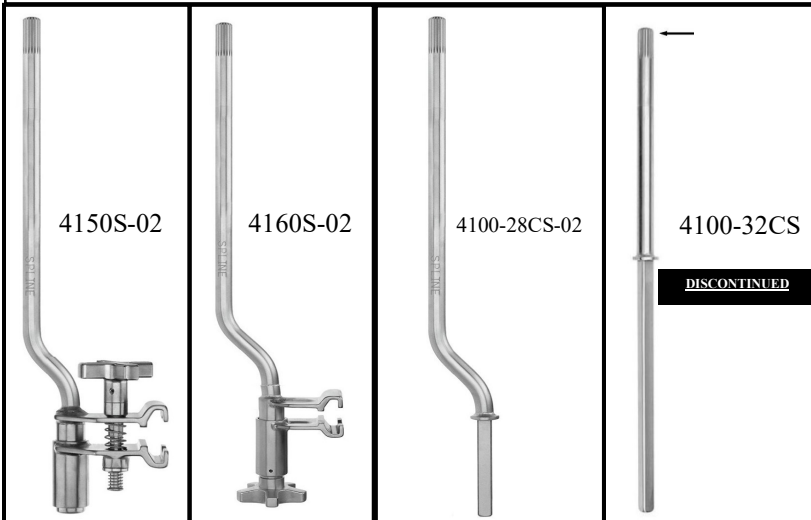

- | | |
|--------------|--|
| 4150S-02 | Spline Tip, Single Bend Post/Clamp, Scrub Applied |
| 4160S-02 | Spline Tip, Single Bend Post/Clamp, Circulator Applied |
| 4100-28CS-02 | Spline Tip Single Bend Bottom Post (square base) |
| 4100-32CS | Spline Tip Bottom Post w/ collar (square base) |

DO NOT REMOVE RETAINING SCREWS

Cleaning:

- Do not disassemble Tilting Post for cleaning.
- Do not remove retaining screws.
- Do not open or close knobs completely.
- Loosen knobs for partial separation.
- Sections and knobs should have free movement.

ONE PIECE POST:
4100-08

THIS ITEM HAS BEEN DISCONTINUED BY THE MANUFACTURER

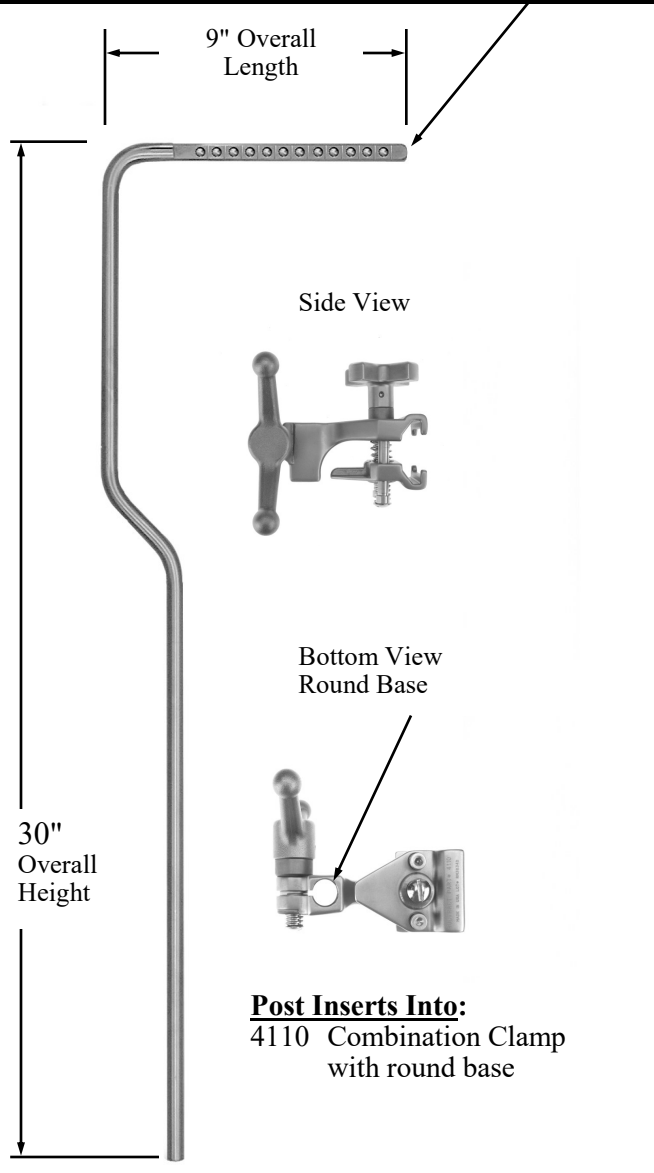

One Piece Post

Either post can be used with a Rultract® round base Combination Clamp. The post is inserted into the clamp to desired height. Tighten securely. Drape per OR protocol.

Post Inserts Into:
4110 Combination Clamp
with round base

RULTRACT® SQUARE AND SPLINE TIP STRAIGHT BOTTOM POST

THESE ITEMS HAVE BEEN DISCONTINUED BY THE MANUFACTURER

4100-32C
Square Tip Bottom Post With Collar
(round base) 5/8" Dia. x 20" long

Post is used with a Rultract® round base combination clamp. For proper locking, post must be inserted flush with bottom of clamp or lower. Tighten securely. Drape per OR protocol.

4100-32CS
Spline Tip Bottom Post With Collar
(square base) 5/8" Dia. x 20" long

Post is used with a Rultract® square base combination clamp. Flat on stop collar** must be facing away from the OR table for proper orientation of spline tip. For proper locking, post must be inserted flush with bottom of clamp or lower. Tighten securely. Drape per OR protocol.

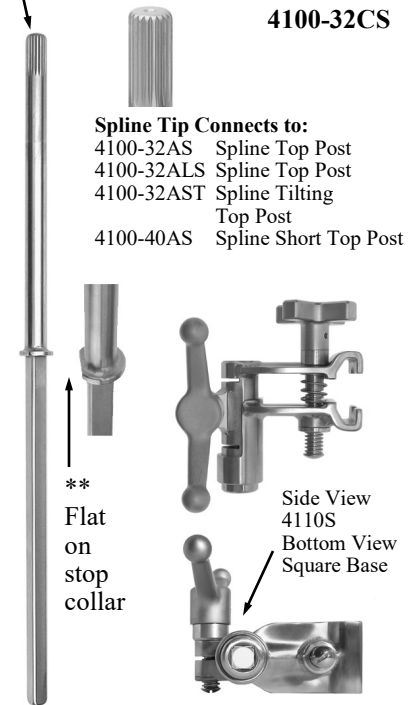
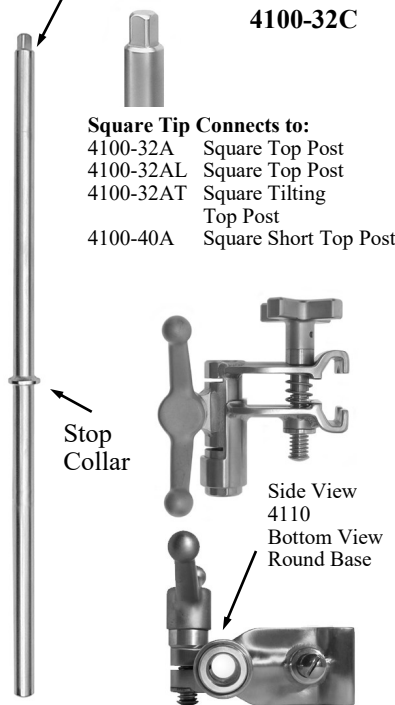

RULTRACT® SQUARE AND SPLINE TIP DOUBLE/SINGLE BEND BOTTOM POSTS

4100-28C
Square Tip Double Bend
Bottom Post (square base)
5/8" Dia. x 18" long

Post is used with a Rultract® square base combination clamp. Lower post to stop collar. Tighten securely. Drape per OR protocol.

4100-28CS-02
Spline Tip Single Bend
Bottom Post (square base)
5/8" Dia. x 18" long

Post is used with a Rultract® square base combination clamp. Lower post to stop collar. Tighten securely. Drape per OR protocol.

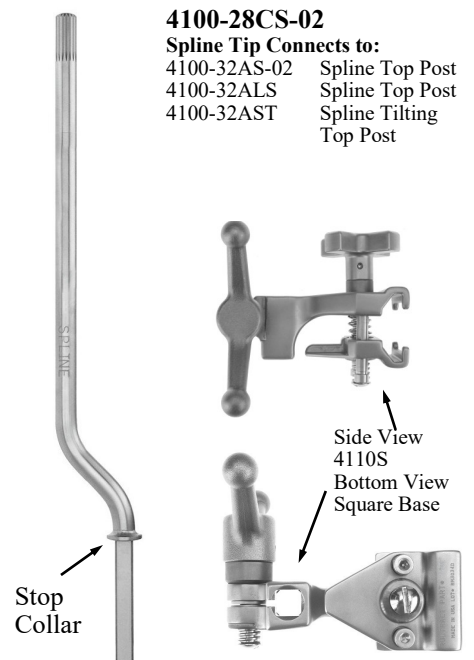
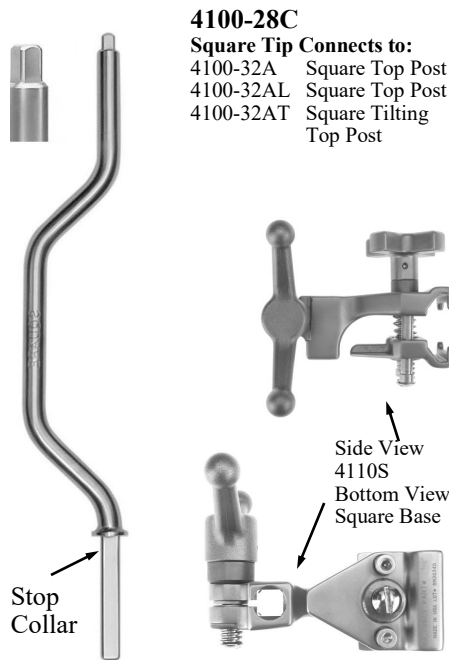

LOCK KNOB INSTRUCTIONS:

Lock Knob components consist of: Gearbox, Extender Bars and Coupler Tube.

The nonremovable Lock Knob is used to tighten components securely on the Rultract® Systems. The Lock Knob (Fig. 01) is threaded with a knurled surface for hand tightening. The tip of the knob is designed to fit into a detent of the square bar. The Lock Knob is retained with roll pins (see p. 05).

Back out (open) the nonremovable Lock Knob until it stops (Fig. 02). Slide the component onto square bar to desired location. The Lock Knob is used to secure component. To properly secure, tip of Lock Knob must completely enter the detent as you tighten. Note closed position of Lock Knob when attached to bar (Fig. 03).

Fig. 01

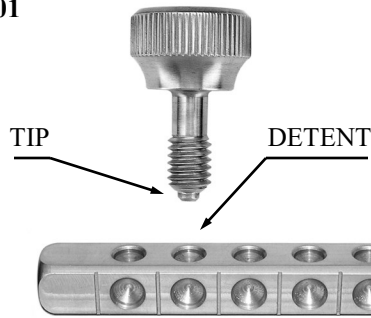

Lock Knob Opened

Fig. 02

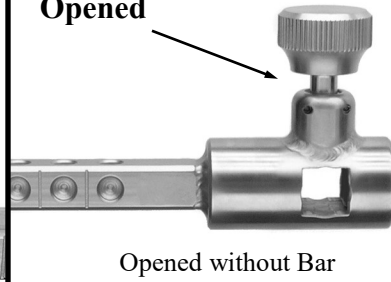

Lock Knob Closed

Fig. 03

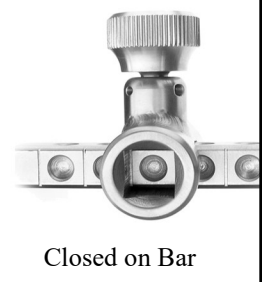
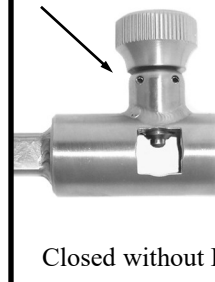

EXTENDER BAR: #4100-39S

To properly lock an Extender Bar in the selected position the tip of the Lock Knob must enter the detent as you tighten securely. Note Lock Knob opened (Fig. 02) and Lock Knob closed (Fig. 03).

(Fig. 04): Horizontal Position Into Hub

Back out nonremovable Lock Knob until it stops. With Lock Knob in vertical position slide hub onto post until it stops. Hand tighten knob securely.

(Fig. 05 & 06): Horizontal Position Thru Cross Square for Right Angle Extension

Back out nonremovable Lock Knob until it stops. With Lock Knob in vertical position slide cross square onto post to desired location **over a detent**. Hand tighten knob securely. See Extender Bar End View Over Detent.

CAUTION: Lock Knob **must** be inserted in a detent for secure placement of accessories.

Fig. 04 Horizontal Position Into Hub

One Extender Bar Attached to Top Post

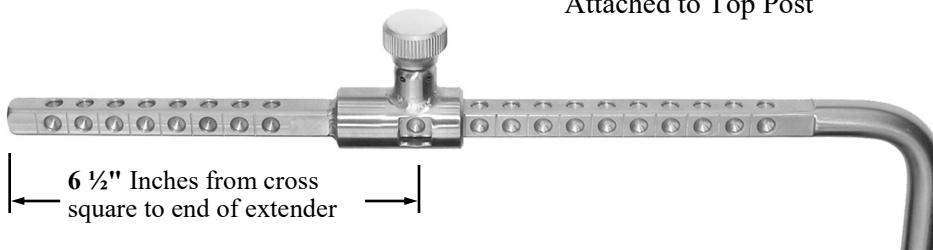

Two Extender Bars Attached to Top Post

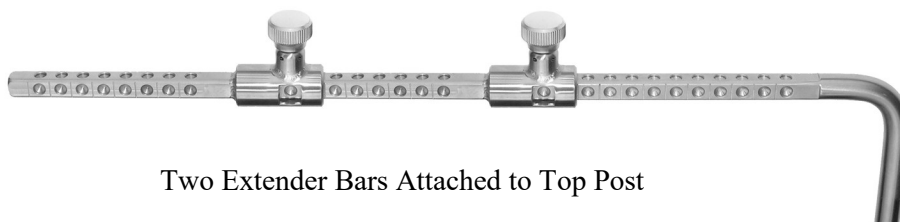

Fig. 05



Horizontal Position Thru Cross Square for Right Angle Extension

Fig. 06



Extender Bar End View Over Detent

ROTATING EXTENDER BAR: #4100-39TS

The squared section of this bar rotates 360 degrees with positive locking every 12 degrees. To rotate, **loosen the attached Rotating Knob** by turning counter clockwise **until it stops**. The toothed sections are spring loaded to help separate the two halves. Once separated the squared section can be rotated freely. When the desired position is obtained, tighten the knob by turning clockwise. When tightened, the teeth mate and the unit is secure.

(Fig 01) Rotating Vertical Position Thru Cross Square

Back out nonremovable Lock Knob until it stops. With Lock Knob at side position slide cross square onto post to desired location **over a detent**. Hand tighten knob securely.

(Fig 02) Right Angle Horizontal Position Into Hub

Back out nonremovable Lock Knob until it stops. With Lock Knob in vertical position slide hub onto post until it stops. Hand tighten knob securely.

(Fig 03) Horizontal Position Thru Cross Square

Back out nonremovable Lock Knob until it stops. With Lock Knob in vertical position slide cross square onto post to desired location **over a detent**. Hand tighten knob securely.

CAUTION: Lock Knob **must** be inserted in a detent for secure placement of accessories.

Fig. 01 Rotating Vertical Position Thru Cross Square
Gain two inches in height

Inverted Position

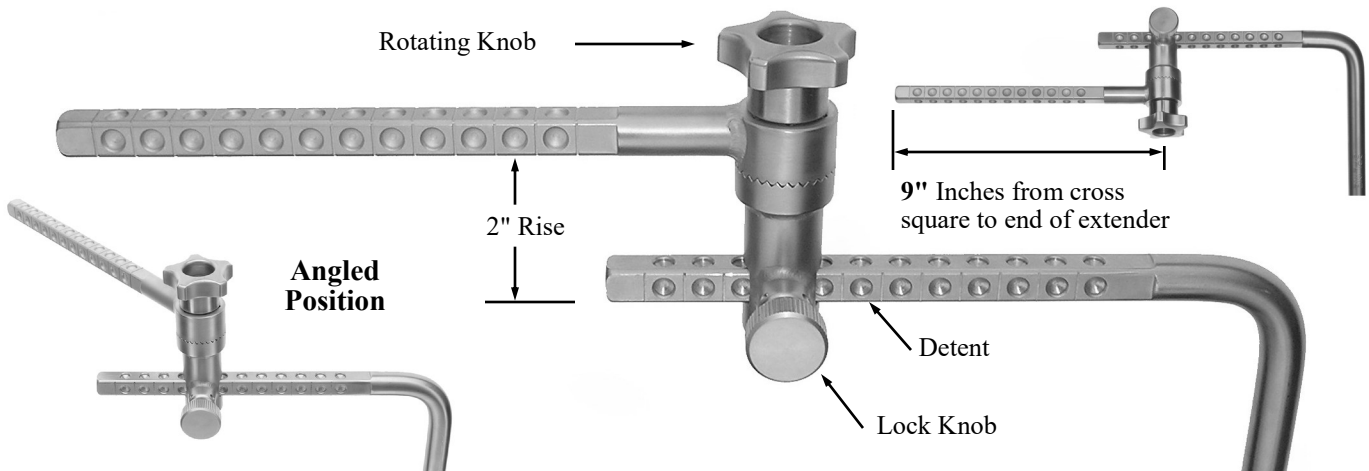
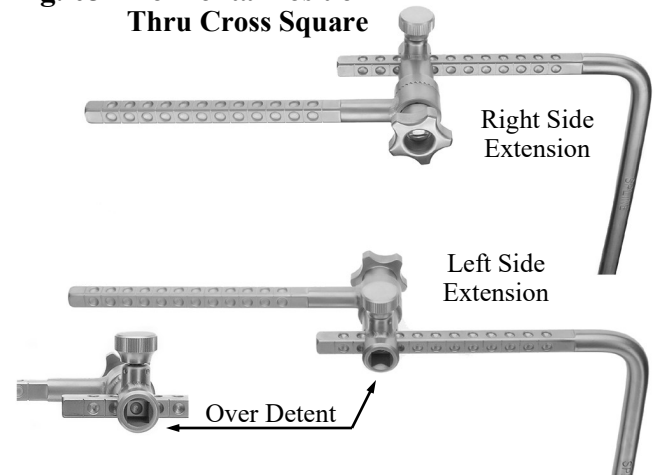
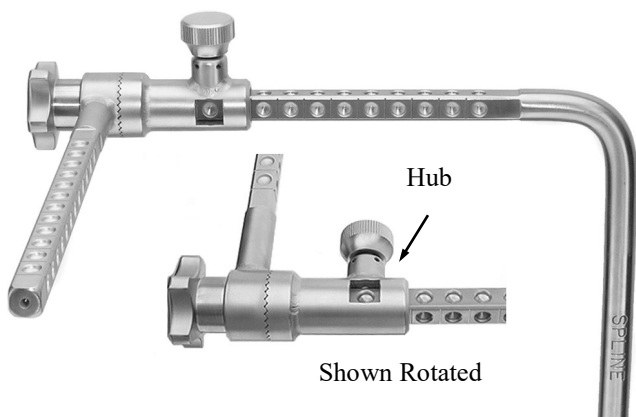

Fig. 02 Right Angle Horizontal Position Into Hub

Fig. 03 Horizontal Position Thru Cross Square



RISER EXTENDER BAR: #4100-39R

(Fig. 01) Vertical Position Thru Hub

Back out nonremovable Lock Knob until it stops. With Lock Knob in vertical position slide hub onto post to desired location **over a detent**. Hand tighten knob securely.

(Fig. 02) Right Angle Vertical Position Thru Cross Square

Back out nonremovable Lock Knob until it stops. With Lock Knob in vertical position slide cross square onto post to desired location **over a detent**. Hand tighten knob securely.

(Fig. 03) Horizontal Position Thru Hub

Back out nonremovable Lock Knob until it stops. With Lock Knob in the horizontal position slide hub onto post to desired location **over a detent**. Hand tighten knob securely.

CAUTION: Lock Knob **must** be inserted in a detent for secure placement of accessories.

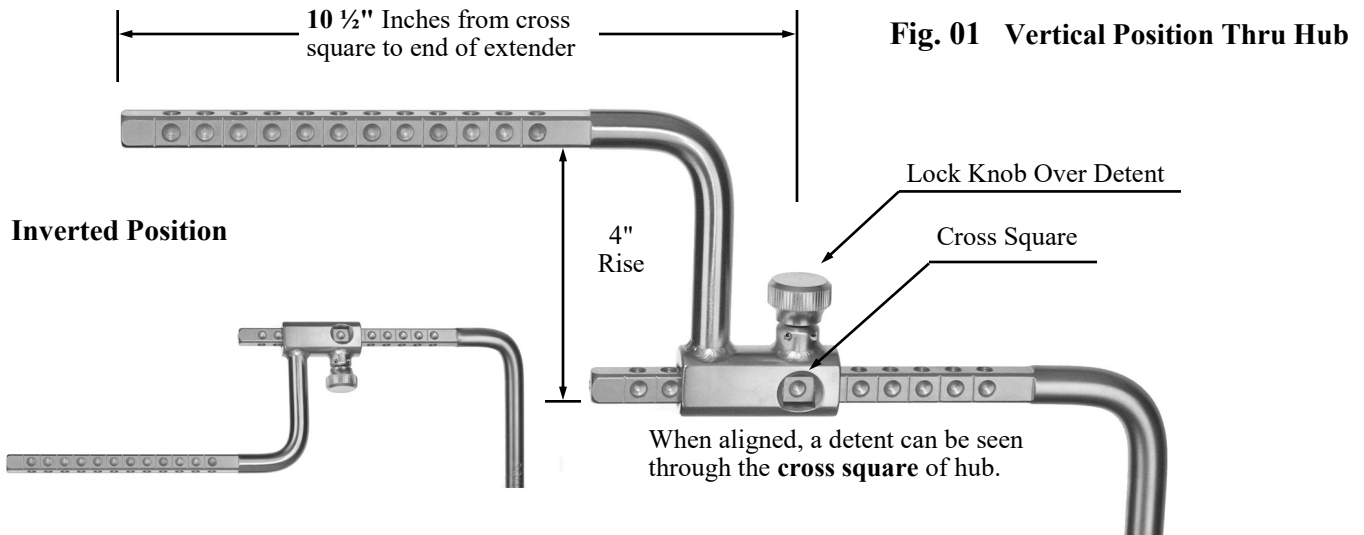

Fig. 02 Right Angle Vertical Position Thru Cross Square

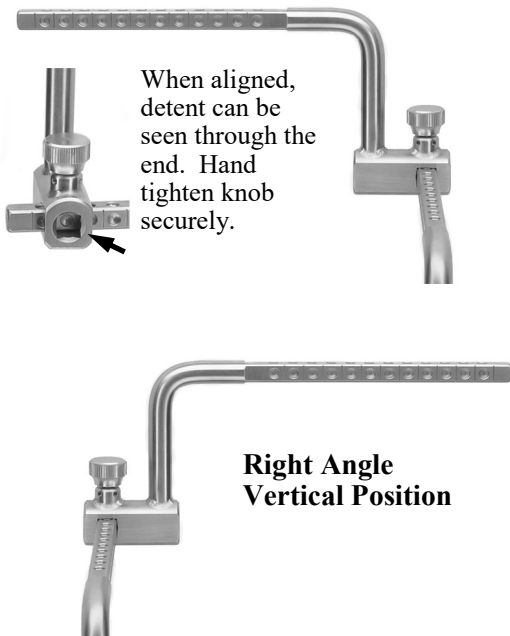
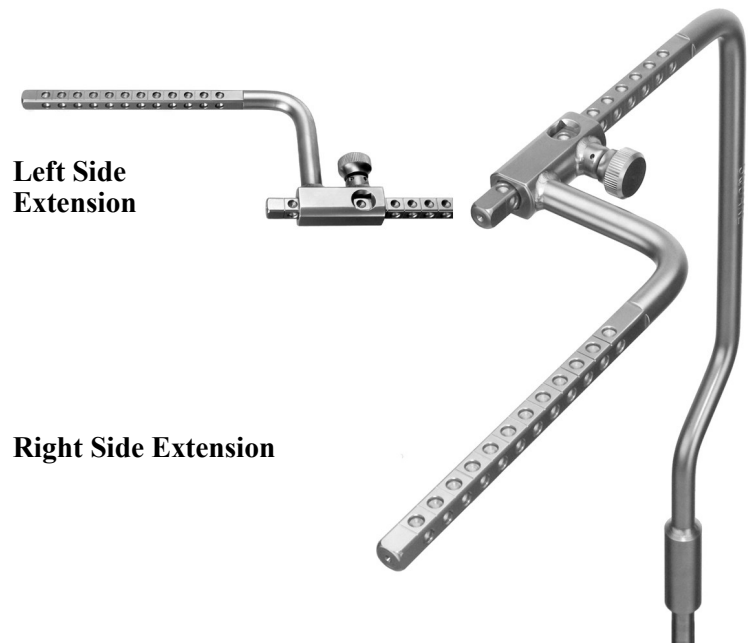

Fig. 03 Horizontal Position Thru Hub



RULTRACT® RETRACTOR CABLE REPLACEMENT INSTRUCTIONS

Rultract, Inc. is the **ONLY** authorized service center in the U.S.A.

When your Rultract® instrument needs repair or service, contact Rultract Inc. All instruments must be decontaminated before being returned for service. Repair charges will apply to instruments repaired outside the warranty. **Any modification or alteration by user or unauthorized service vendor will void all warranties and release Rultract® from any liability.**

SERVICE INTERVAL: Complete factory service of your Rultract Skyhook Retractor System (including a cable change):

****If using a surgical device tracking system to track cases, i.e. Censitrac: 400 cases.**

****If not using a surgical device tracking system to track cases, i.e. Censitrac: Every 12-24 months dependent on frequency of use.**

WARNING: Cables worn or damaged through mishandling *prior to the factory service interval*, must be replaced with a **new Rultract® cable**. Do not attempt to repair, cut, alter or modify the cable in any way. **Cutting and reattaching the cable will cause it to weaken and fray. This will result in failure during use.**

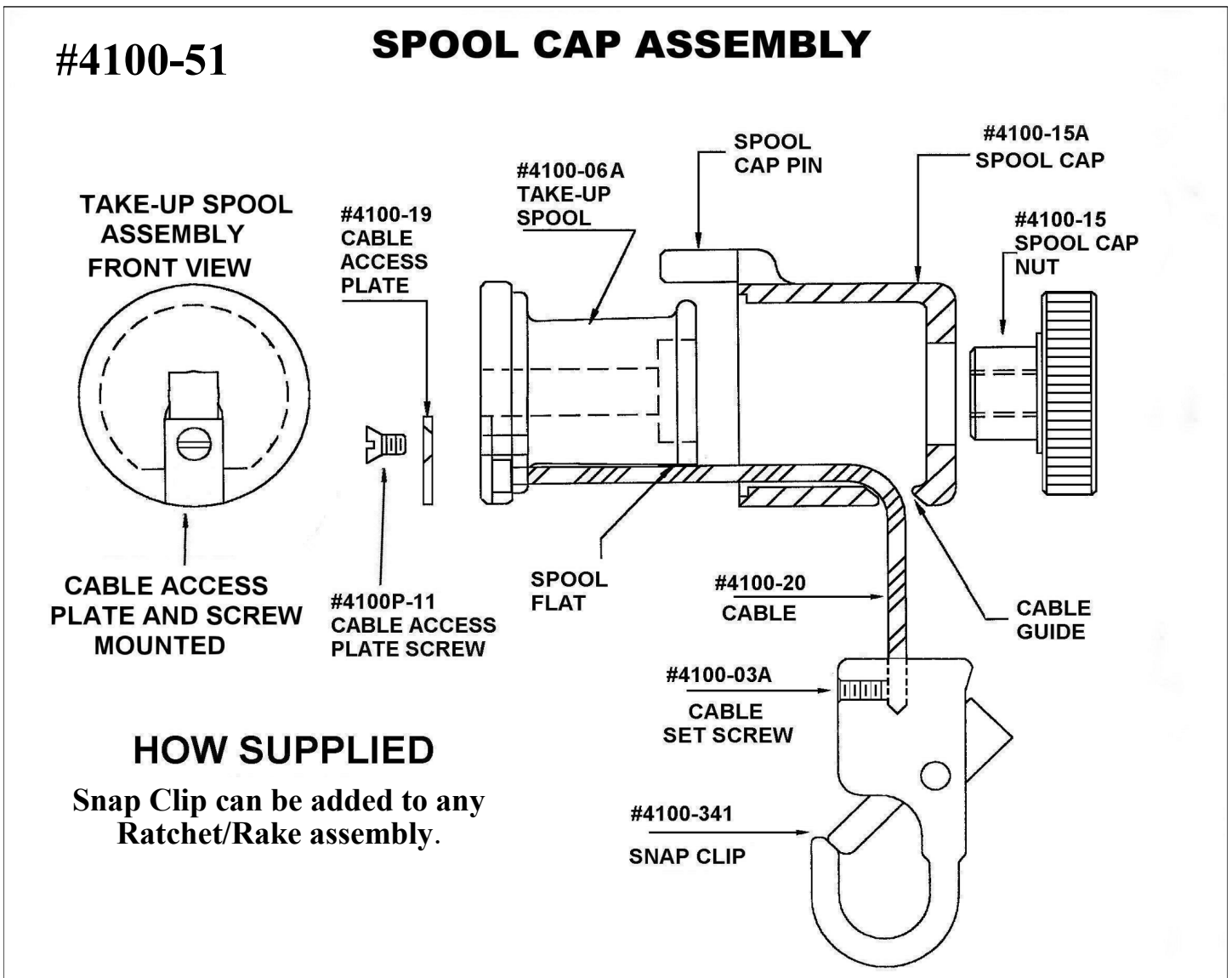

STEP 1 PULL CABLE FROM SPOOL : While holding the Ratchet by the Spool Cap Assembly, shift Ratchet Lever to reverse direction (Fig. 01). Pull down on Snap Clip or Rake Plate Assembly to **completely unwind the cable, approximately 16" (Fig. 02)**. If cable is jammed or will not unwind freely, proceed to the next step and remove the Spool Cap Assembly. **Note: Worn or Damaged cable must be replaced at this time with a new Rultract® Cable.**

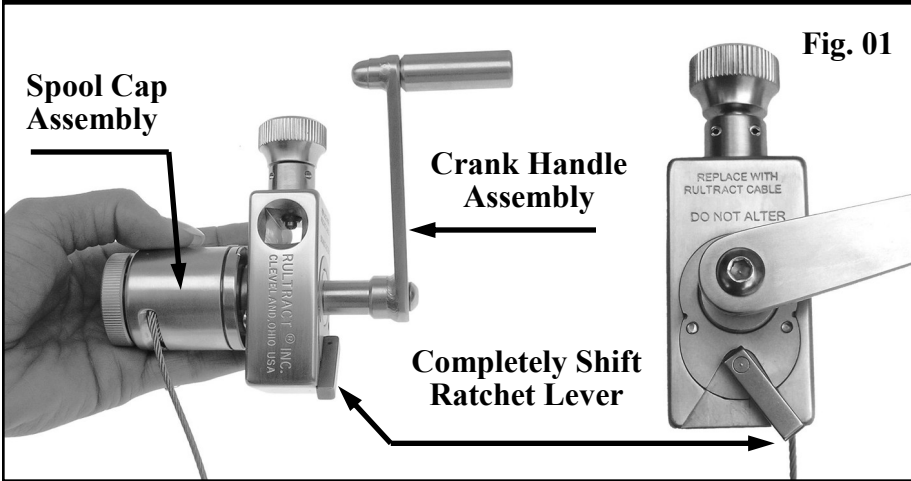
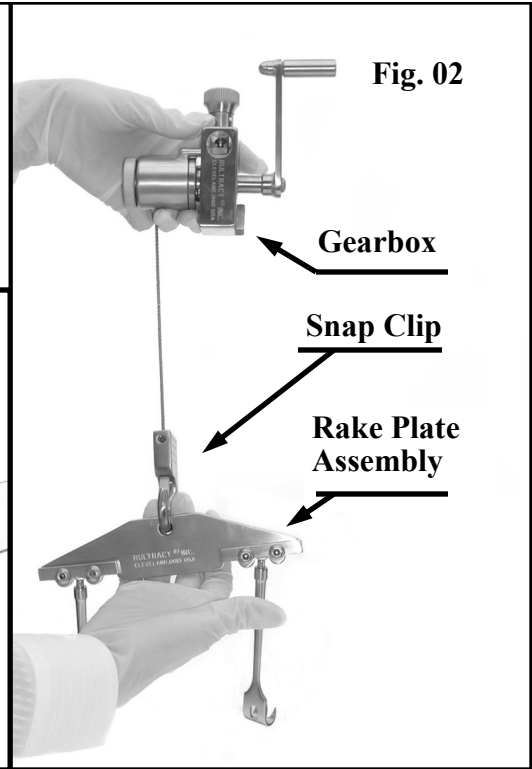

STEP 2 REMOVE SPOOL CAP AND CRANK HANDLE ASSEMBLY:

Holding the Crank Handle Assembly as shown, unscrew and remove the Spool Cap Nut using a counter clockwise rotation (Fig. 03 & 04). Slide Spool Cap Assembly from shaft of Crank Handle Assembly (Fig. 05). Slide Crank Handle Assembly out of Gearbox. At this time, note square of shaft and square hole in Gearbox (Fig. 06).

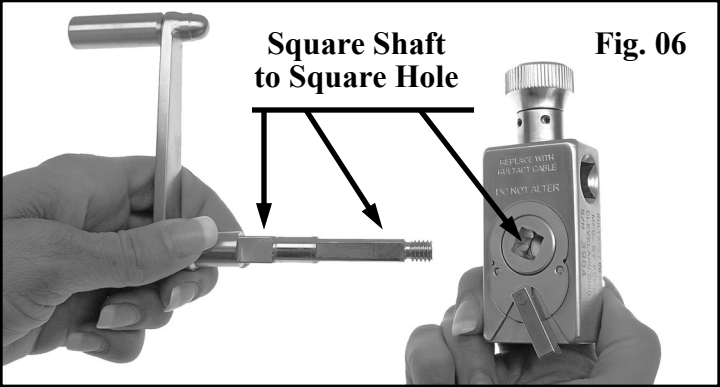
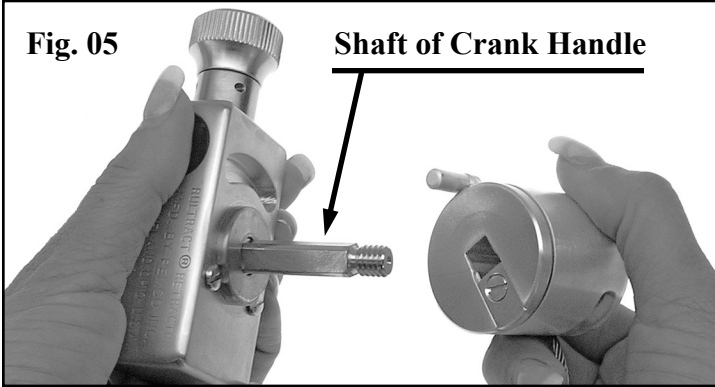
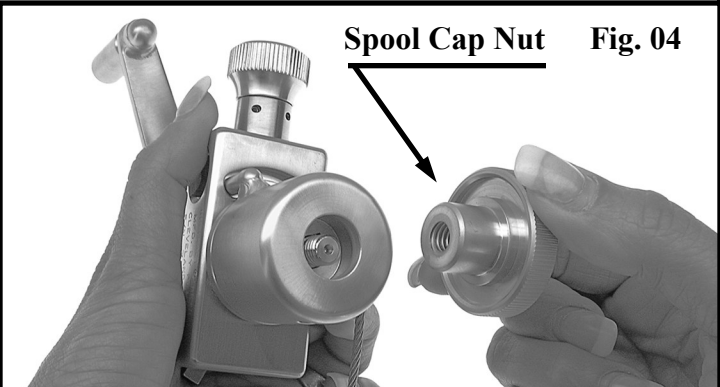

CAUTION: Always insert spool cap pin into the groove of the gearbox. Failure to do so may result in disassembly or damage to the unit.

STEP 3 REMOVE CABLE FROM PIVOT HUB OR SNAP CLIP:

With Cable completely unwound, hold Pivot Hub or Snap Clip in one hand. Insert 1/8" allen wrench (supplied with cable replacement pack) into Cable Set Screw (Fig. 07 or 08). Loosen a minimum of two full turns. It is not necessary to completely remove set screw. To remove Cable, hold the Spool Cap Assembly in one hand and pull on hub (Fig. 09). **Note:** Set Screw has created an upset in the existing cable (Fig. 10).

WARNING: Always wear eye protection when removing cable.

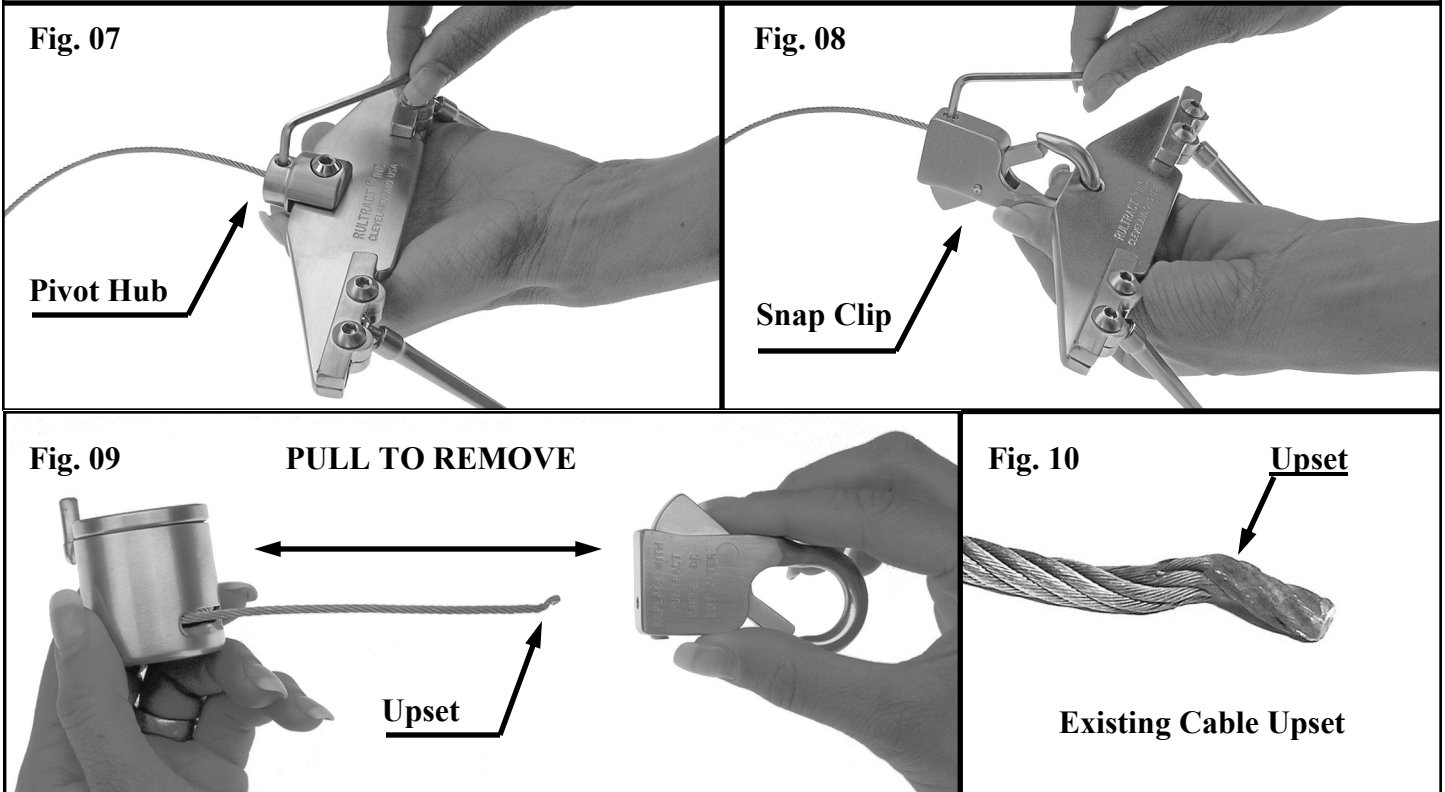

STEP 4 SEPARATE SPOOL CAP AND TAKE UP SPOOL:

Pull Cable completely through the Spool Cap cable guide (Fig. 11). At this time note the flat surface of the Spool.

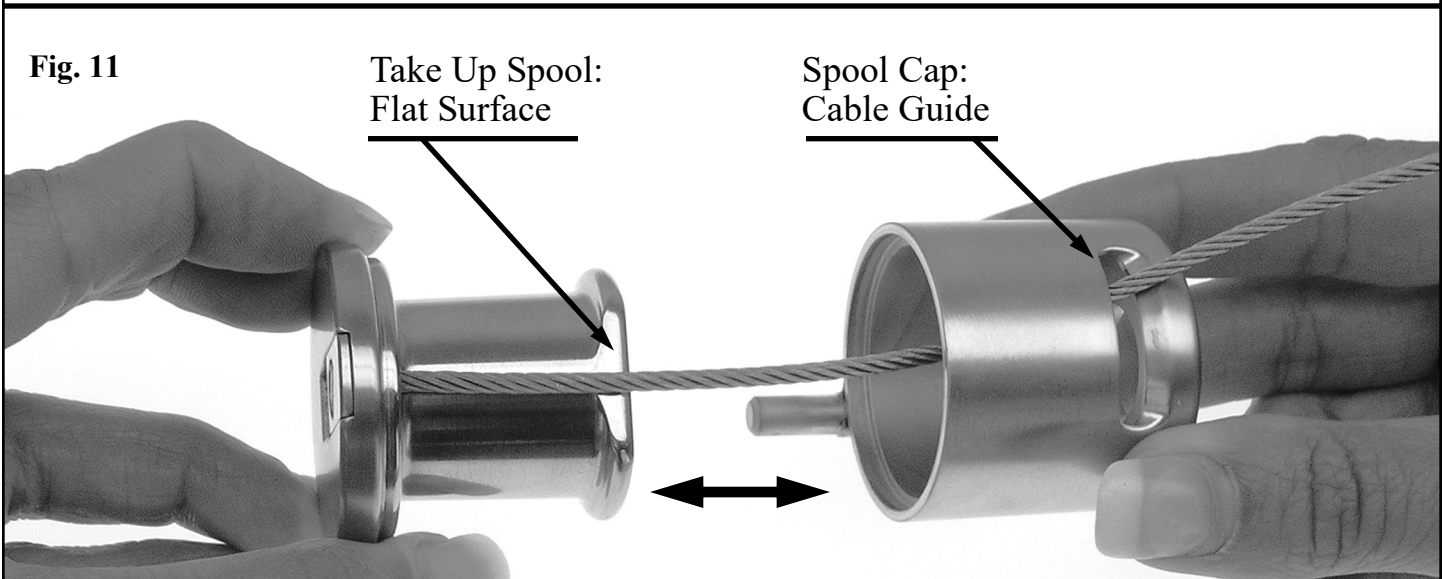

STEP 5 REMOVE CABLE FROM SPOOL:

While holding the Spool, remove the Cable Access Plate Screw and Cable Access Plate (Fig. 12). Note: Orientation of Cable Access Plate and screw, flush with all surfaces. Cable Bushing is seated in Spool (Fig. 13). Pull Cable through the hole (Fig. 14).

Cable Access Screw and Plate

Cable bushing seated in Spool

Direction of pull

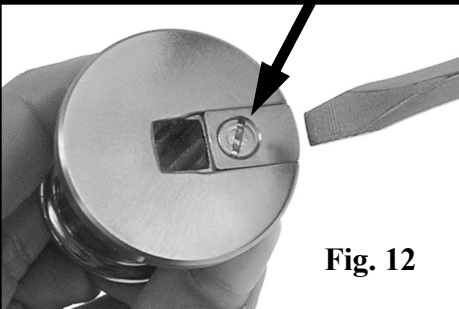

Fig. 12

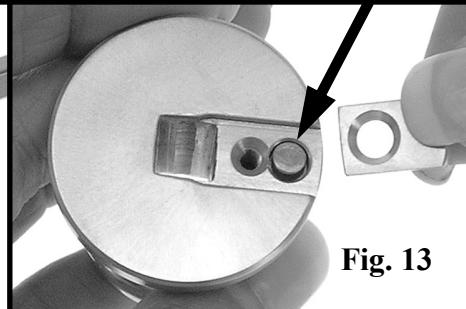

Fig. 13

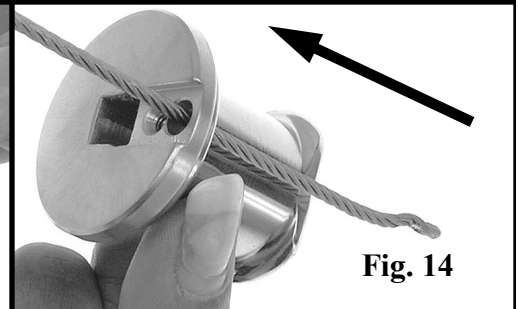

Fig. 14

STEP 6 INSTALL CABLE:

Insert tip of a **new Rultract® cable** through the same hole (Fig. 15). Assure the Cable Bushing is properly seated. Replace the Cable Access Plate (**recess side up**) and loosely insert Cable Access Plate Screw. Push outer edge of Cable Access Plate inward when tightening screw (Fig. 16). This will assure the edge of the Cable Access Plate is flush with the edge of the Spool. Note: After Cable Access Plate is tightened, cable must spin freely (Fig. 17).

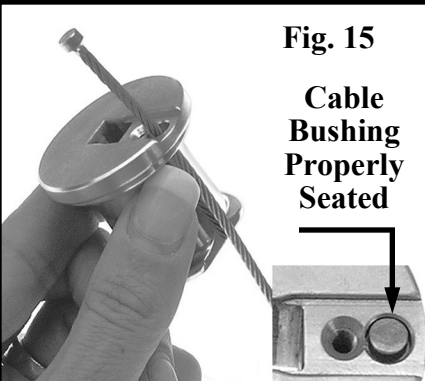

Fig. 15

Cable Bushing Properly Seated

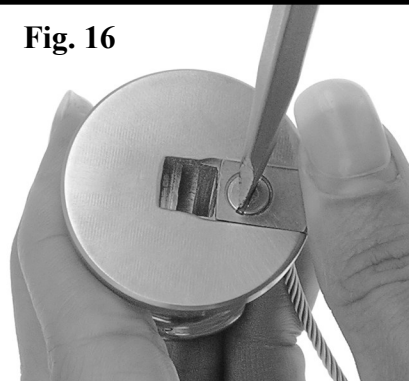

Fig. 16



Cable must spin freely Fig. 17

STEP 7 REASSEMBLE SPOOL CAP AND SPOOL:

Insert **new Rultract® Cable** into largest opening of Spool Cap and through the Cable Guide (Fig. 18). Align the Cable Guide with the flat surface of the Spool and slide the two pieces together (Fig. 19).

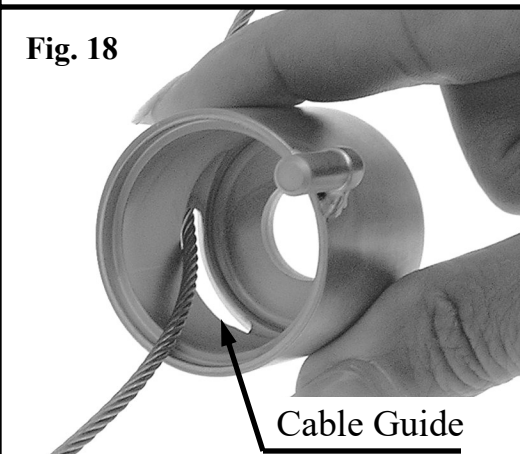

Fig. 18

Cable Guide

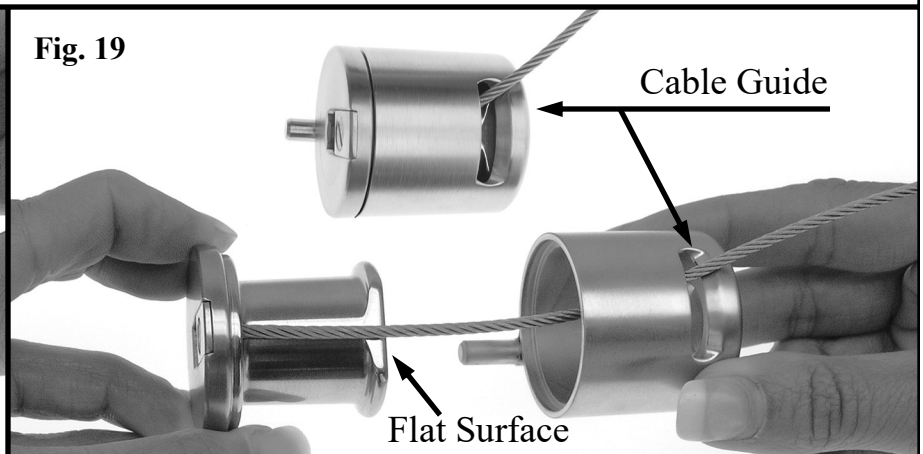

Fig. 19

Cable Guide

Flat Surface

STEP 8 INSTALL CRANK HANDLE ASSEMBLY, SPOOL CAP AND SPOOL CAP NUT:

Slide the shaft of the Crank Handle Assembly into Gearbox by inserting the squared end into the square hole located above the Ratchet Lever (Fig. 20). **Note:** Both squared sections of the shaft must be completely inserted and flush. While holding the Gearbox and Crank Handle together, line up Spool Cap Pin with the groove in the Gearbox. Slide the Spool Cap Assembly onto the shaft (Fig. 21). Spool Cap Pin must be inserted into groove of Gearbox. While holding Crank Handle Assembly and Gearbox firmly, screw the Spool Cap Nut onto the shaft by turning clockwise. **Hand tighten securely (Fig. 22).**

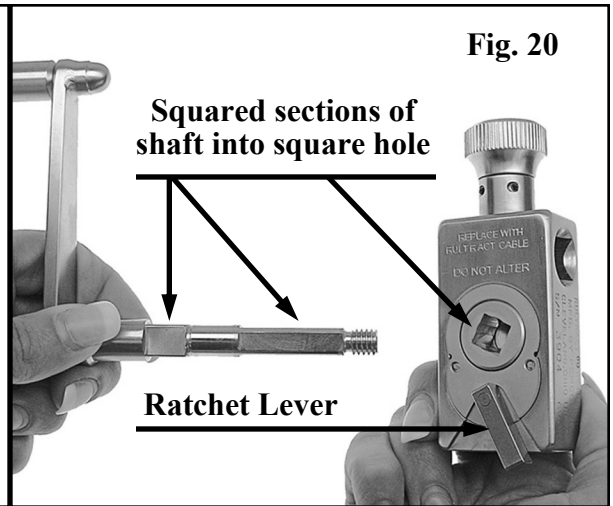

Fig. 20

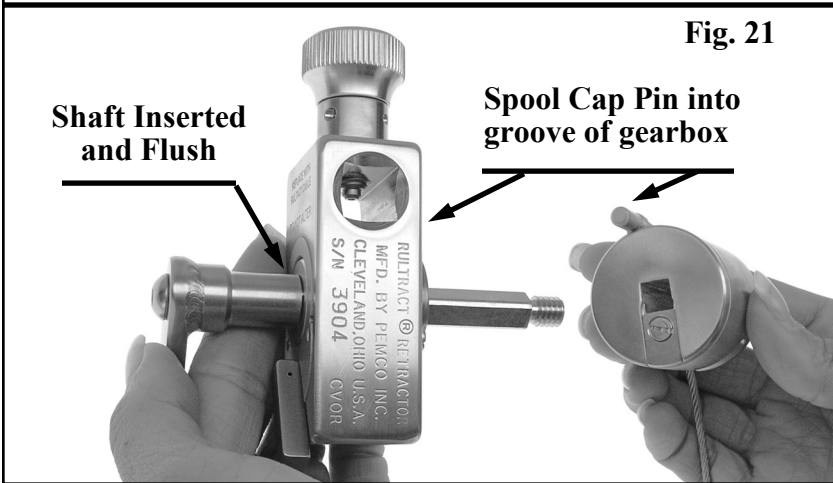

Fig. 21

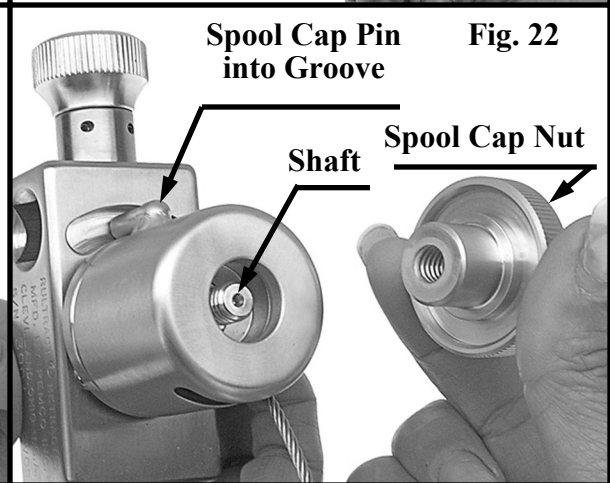

Fig. 22

STEP 9 CABLE INSERTION INTO SNAP CLIP OR PIVOT HUB:

Insert the **new Rultract® cable** completely into the hole until it stops, approximately 1/2" deep. **Make sure set screw is not blocking cable (Fig 23).** Proper tightening of the cable will require some force to compress the cable. Holding the rake plate securely will give the correct amount of leverage. Turn set screw until it makes contact with the cable. **Note** position of allen wrench and tighten set screw 1 to 1 1/2 turns (Fig. 24). Proper tightening of the set screw creates an **upset**, which properly retains the cable. Once the set screw has been tightened do not reposition cable.

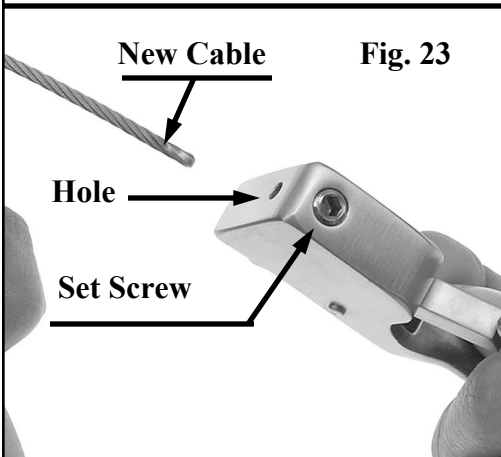

Fig. 23

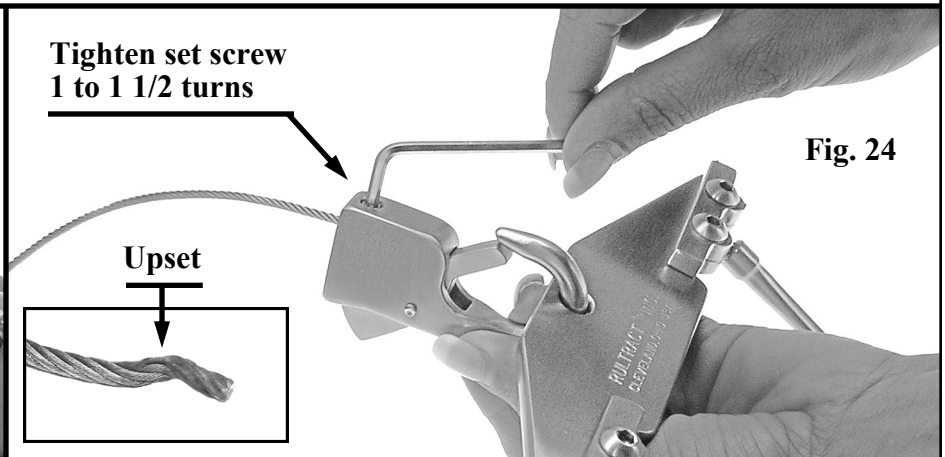

Fig. 24

STEP 10 TEST WINDING FUNCTION:

Allow rake plate to hang freely**. Weight of Rake Plate allows for proper alignment of Cable on Spool. Total length of exposed, unwound Cable is approximately 18 inches (Fig. 25). Note: Leave one to two inches of Cable exposed to prevent flexing of Cable on Cable Guide at insertion site (Fig. 26). This position protects the Cable from kinking and allows gas or steam to penetrate during sterilization.

DEMONSTRATION
 PROPER ALIGNMENT OF
 CABLE ON SPOOL WHEN
 WOUND CORRECTLY.
 Shown without Spool Cap

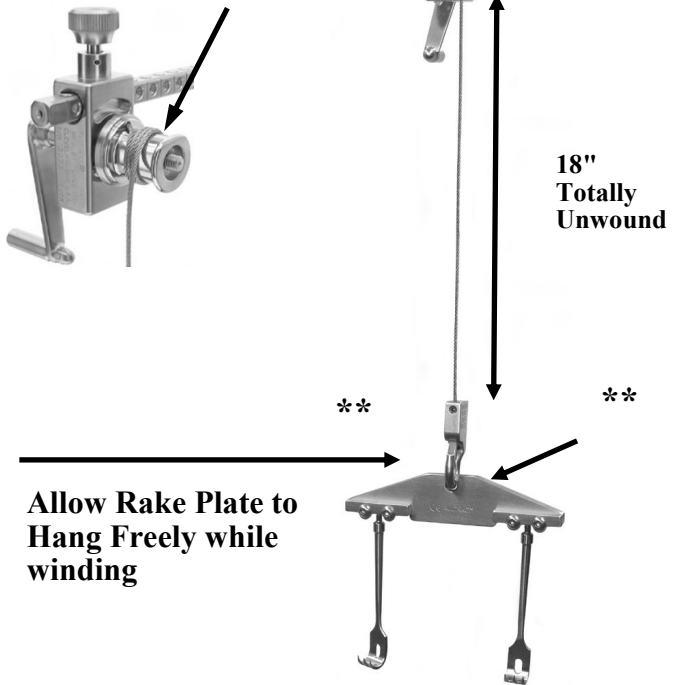
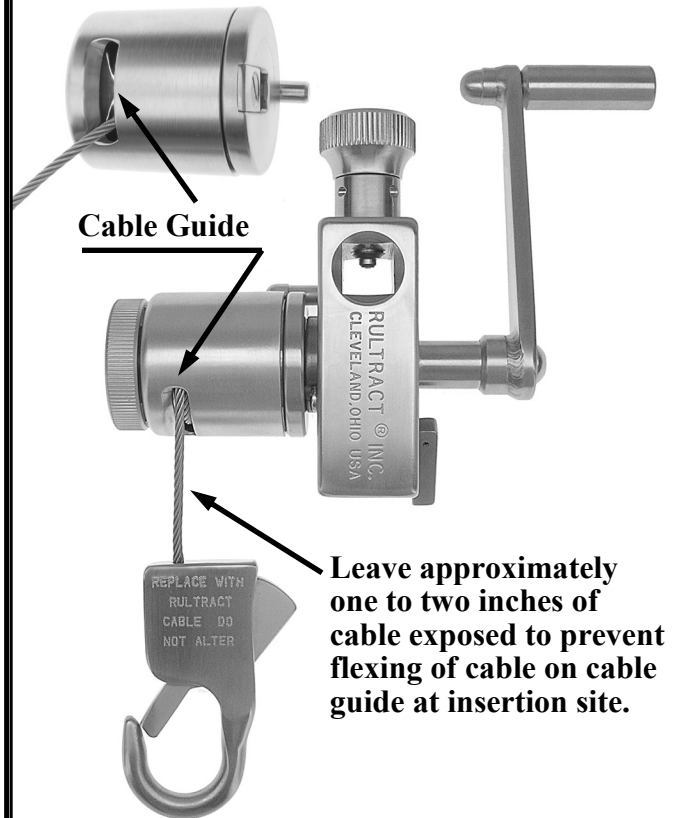

Fig. 25

Fig. 26



HANDLING OF RULTRACT® RETRACTOR CABLE

WARNING: Cables worn or damaged through mishandling *prior to the factory service interval*, must be replaced with a **new Rultract® cable**. Do not attempt to repair, cut, alter or modify the cable in any way. **Cutting and reattaching the cable will cause it to weaken and fray. This will result in failure during use.**

CAUTION:

****Always allow rake plate to hang freely when winding Cable.** The weight of Rake Plate allows for proper alignment of Cable on Spool. Failure to allow the Rake Plate to hang freely may cause the Cable to kink during winding. Leave approximately one to two inches of Cable exposed to prevent flexing of Cable on Cable Guide at insertion site.

CAUTION:

Always insert spool cap pin into the groove of the gearbox. Failure to do so may result in disassembly or damage to the unit.

Rultract Inc. 5663 Brecksville Rd. Cleveland, Ohio 44131 U.S.A.
 Email: rultract@rultract.com Website: www.rultract.com

Cleaning: Rultract® System

Repeated processing has minimal effect on this instrument. End of life is normally determined by wear and damage due to use.

CAUTION: Disassemble unit prior to cleaning. The spool cap nut must be unscrewed to separate the spool, spool cap, crank handle assembly and gearbox assembly (see page 34).

It is not necessary to remove fasteners or roll pins for proper cleaning and sterilization.

Further disassembly is not necessary and may void warranty.

1. Remove excess soil on instrument as soon as is reasonably practical following use.
2. Disassemble Ratchet/Rake per instructions. No disassembly of other products required for cleaning.
3. It is expected that commercially available products for the use of cleaning are used.
4. If using an automated cleaning system (such as a sonicator) use a commercially available detergent approved for automatic use that is ph-neutral or alkaline. Set appropriate wash and rinse cycles according to the manufacturer of the automatic cleaning system's instructions.
5. If cleaning manually, thoroughly clean surface contamination. Soak in a neutral or alkaline pH disinfecting solution or enzymatic cleaner. Do not soak for longer than what is recommended by solution manufacturer.
6. Instrument should be thoroughly rinsed with distilled water after cleaning to remove any residual debris or cleaning agent.
7. Instruments may be lubricated using a small amount of surgical grade lubrication. Let instrument drip dry a few moments before wrapping for sterilization.
8. Visually inspect instrument for any damage prior to use.

Biocompatibility of Rultract's Medical Devices

Rultract uses 420, 304 and 17-4 Stainless Steel in its medical products that would have direct contact with patients

IFU SYSTEM COMPONENTS - PREPARE FOR CLEANING CYCLE

DO NOT REMOVE RETAINING SCREWS

Cleaning / Sterilization: Clamp

- **Do not disassemble for cleaning or sterilization.**
- Do not remove retaining screw(s).**
- Do not open or close handle (s) completely.
- Jaws should be partially opened.
- Jaws and handles should have free movement.

Cleaning / Sterilization: Tilting Top Posts and Rotating Extender Bar

- **Do not disassemble for cleaning or sterilization.**
- Do not remove retaining screw (s).**
- Do not open or close knobs completely.
- Loosen knobs for partial separation.
- Sections and knobs should have free movement.

COMBINATION CLAMP
SCRUB/CIRCULATOR
APPLIED

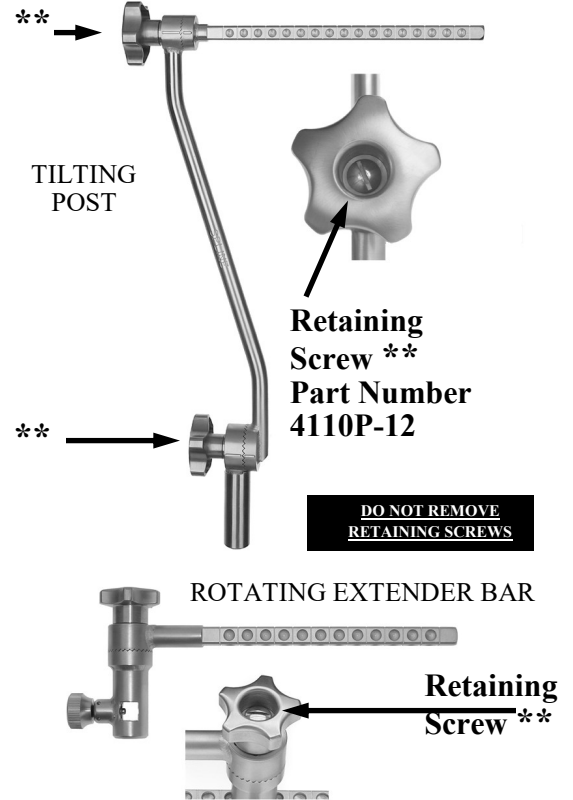
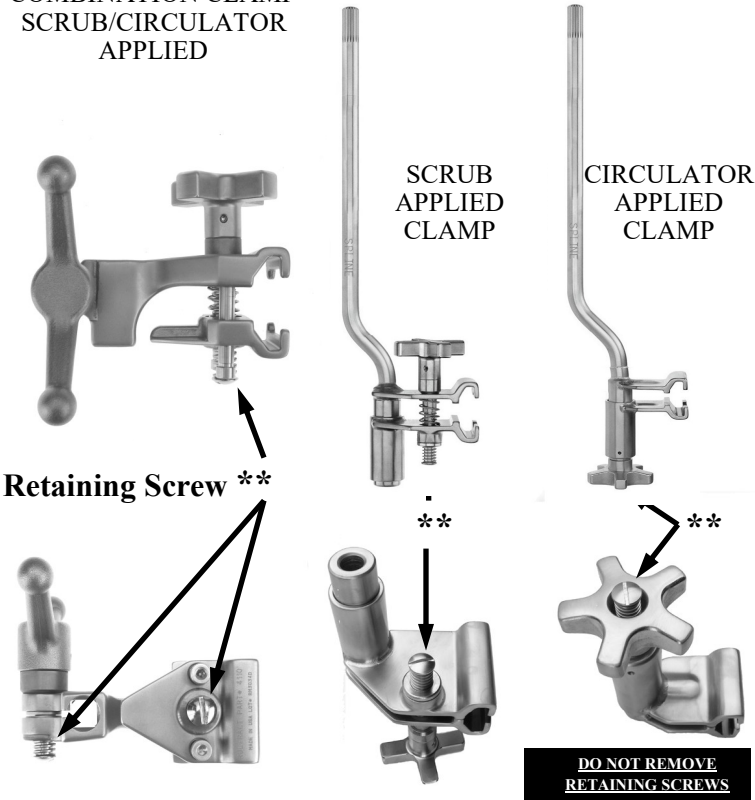

WARNING: Removal of retaining screw (s)** (4110P-12) will cause device to come apart. This will result in failure during use.

CLEANING: Resternotomy Rake Plates

- **No disassembly required**

4100-52RDL 4100-52RDM 4100-52RDS 4100-52RDH

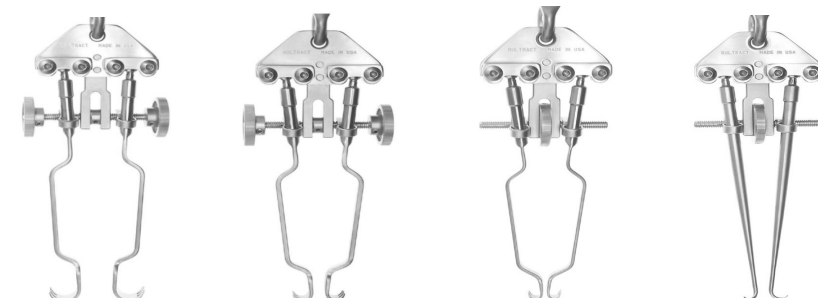

- **Do not disassemble for cleaning or sterilization..**
- Do not remove Rake Clamp screws.**
- Do not open or close knobs completely.
- Sections and knobs should have free movement.

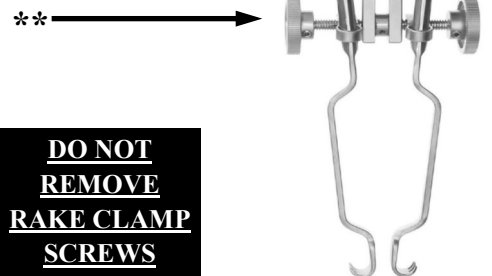

IN PREPARATION FOR THE CLEANING CYCLE, YOU MUST
 DISASSEMBLE RATCHET/RAKE ASSEMBLY, 4100-IMR-6, Fig. 01
 INTO 5 PIECES AS SHOWN IN Fig. 02.

NO FURTHER DISASSEMBLY REQUIRED

Proceed to pages 35-37 for disassembly / reassembly instructions

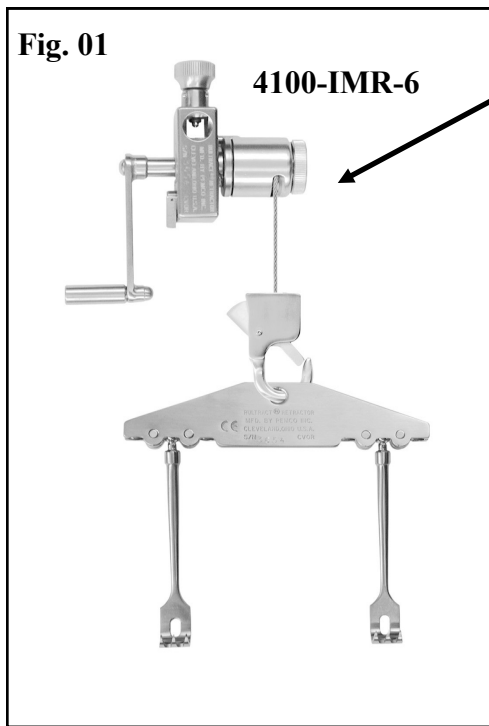

This is disassembled

into these 5 pieces for the Cleaning Cycle...

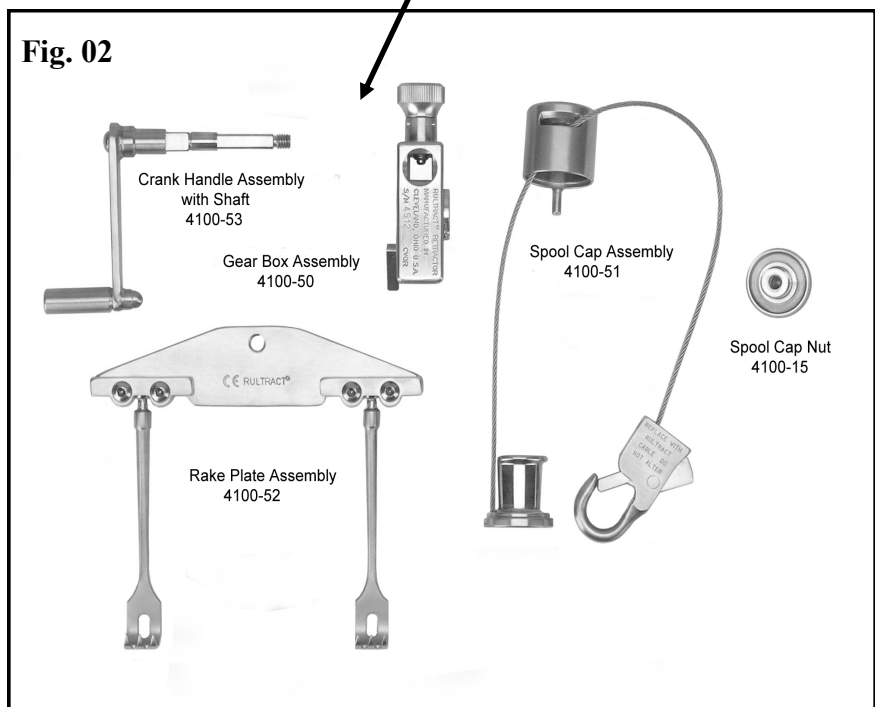

...and then,
 ONCE THE CLEANING CYCLE IS
 COMPLETE,
 reassembled back into this
 for Sterilization and Use.

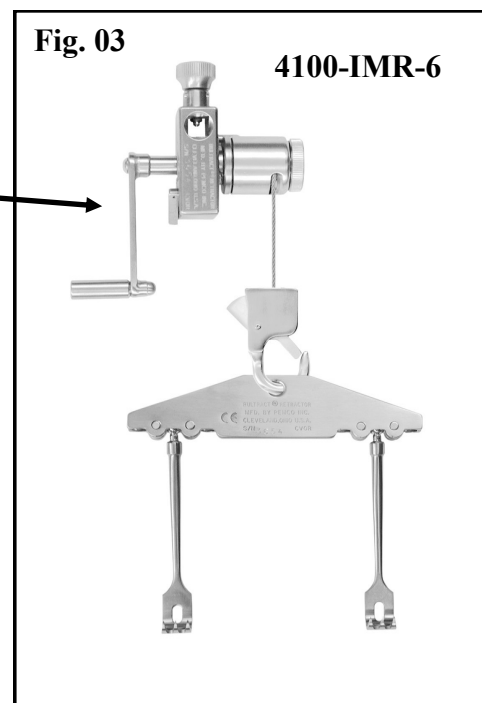

Determine Your Rake Plate System Configuration

STEP 1 RAKE PLATE:

If your system has a Snap Clip and a Rake Plate

Disconnect Rake Plate from Snap Clip

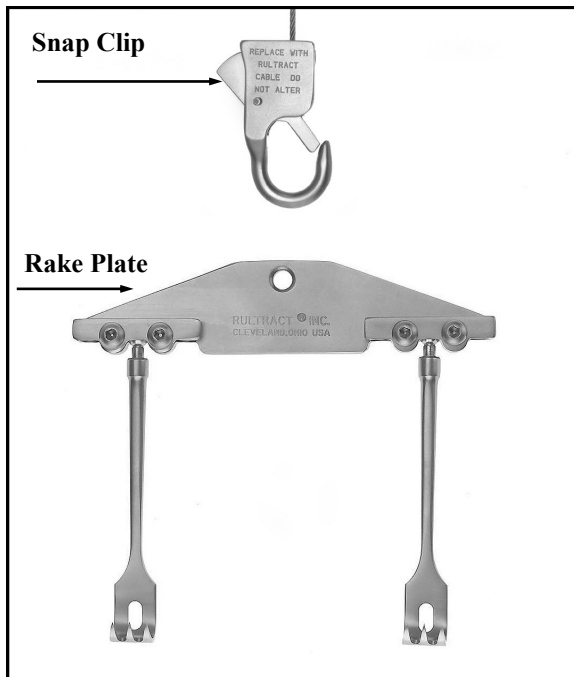

If your system has a Pivot Hub Attached to the Cable and Rake Plate

Do not disassemble Rake Plate from Pivot Hub—Proceed to Step 2

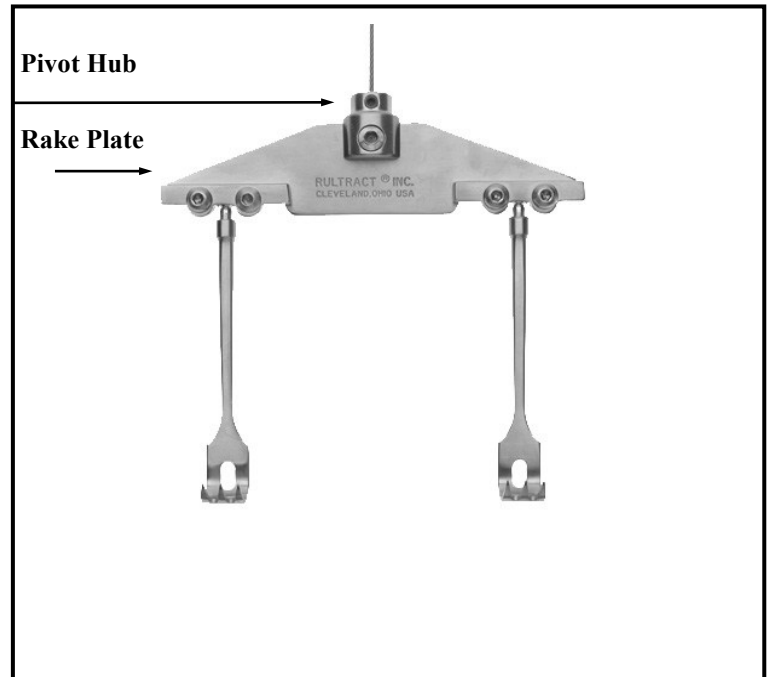

If your system has a Snap Clip Only

Proceed to Step 2



DISASSEMBLE RATCHET FOR CLEANING

STEP 2 PULL CABLE FROM SPOOL : While holding the Ratchet by the Spool Cap Assembly, shift Ratchet Lever to reverse direction (Fig. 01). Pull down on Snap Clip or Rake Plate Assembly to **completely unwind the cable, approximately 16"** (Fig. 02). If cable is jammed or will not unwind freely, proceed to the next step and remove the Spool Cap Assembly. **Note: Worn or Damaged cable must be replaced at this time with a new Rultract® Cable.**

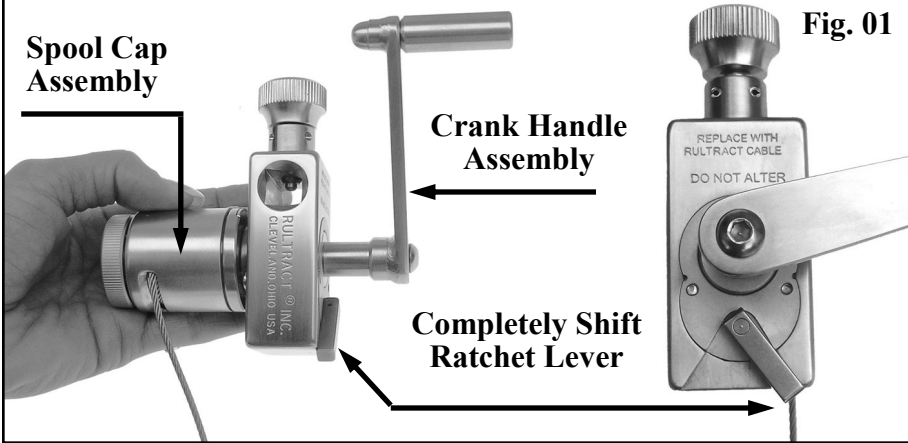
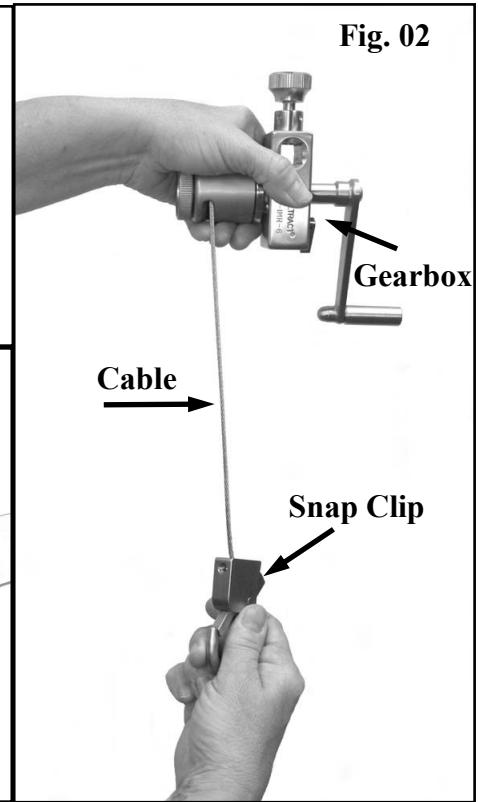

STEP 3 REMOVE SPOOL CAP ASSEMBLY AND CRANK HANDLE ASSEMBLY:

Holding the Crank Handle Assembly as shown, unscrew and remove the Spool Cap Nut using a counter clockwise rotation (Fig. 03 & 04). Slide Spool Cap Assembly from shaft of Crank Handle Assembly (Fig. 05). Slide Crank Handle Assembly out of Gearbox. At this time, note square of shaft and square hole in Gearbox (Fig. 06).

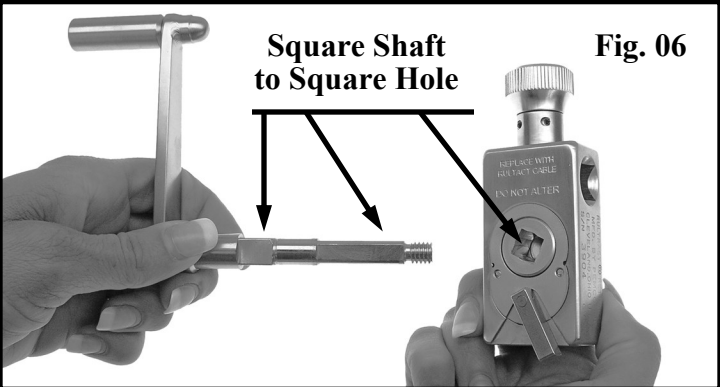
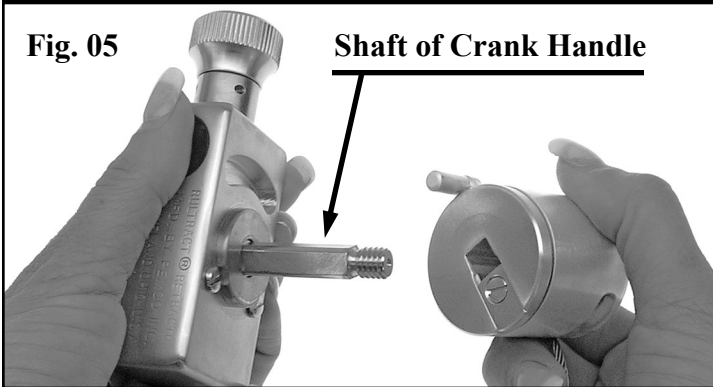
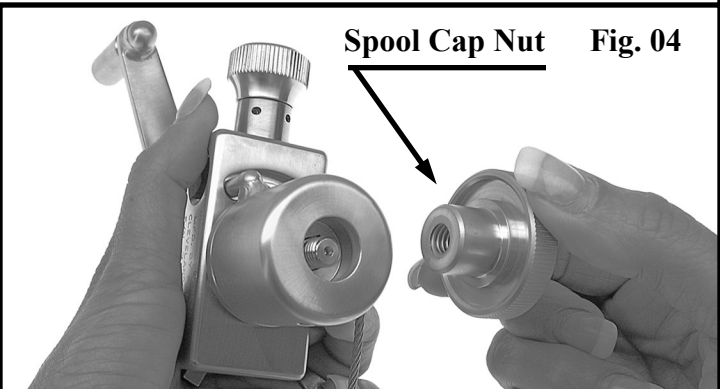

CAUTION: Always insert spool cap pin into the groove of the gearbox. Failure to do so may result in disassembly or damage to the unit.

DISASSEMBLE RATCHET FOR CLEANING (continued)

STEP 4 REMOVE SPOOL CAP FROM SPOOL:

To remove Spool Cap from Spool, line up Cable Guide with Pin and Cable Access Plate of Spool (Fig. 07). This will align flat on Spool with Cable Guide and allow the two pieces to separate (Fig. 08). Slide Spool Cap along cable to rest on Snap Clip or Pivot Hub (Fig. 09).

Fig. 09



Fig. 07

Fig. 08

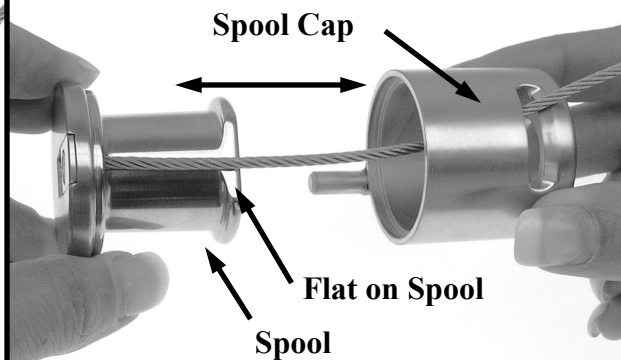
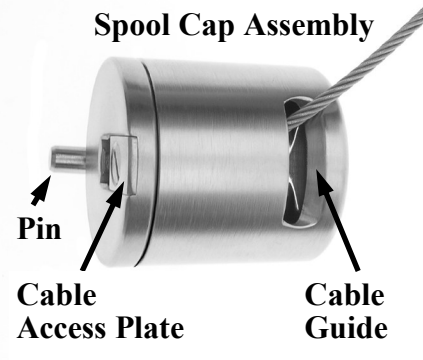
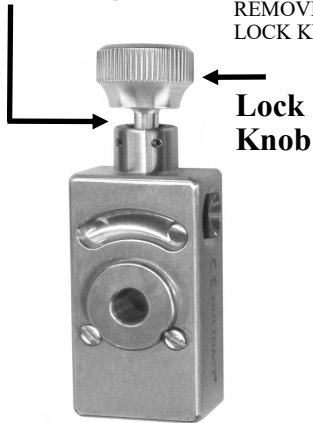

Fig. 10

STEP 5 BACK OUT (OPEN) THE NON-REMOVABLE LOCK KNOB:

The knob should not be open or closed all the way. It should be somewhere in the middle and have some “play” in it. (Fig. 10).

DO NOT REMOVE LOCK KNOB



The Rultract Ratchet Rake Assembly is now completely disassembled into the following 5 pieces and ready to begin the cleaning cycle

NO FURTHER DISASSEMBLY REQUIRED

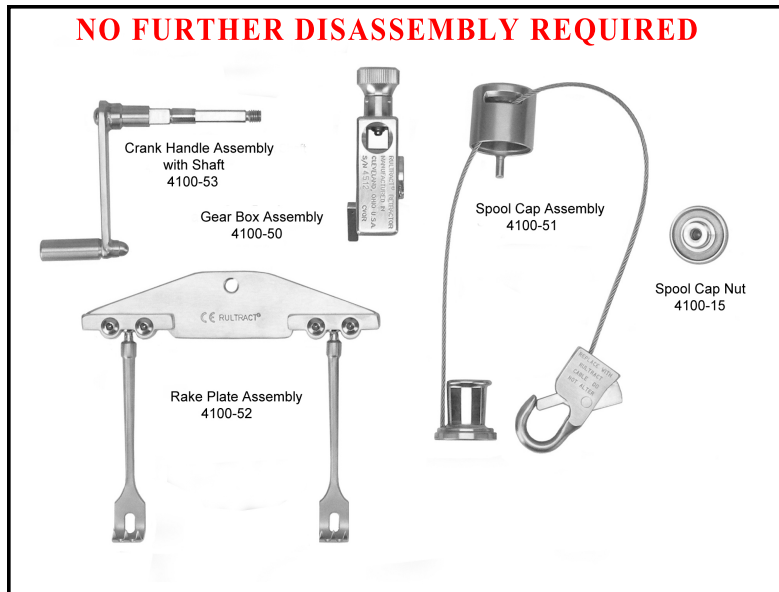

CAUTION:

Check and tighten all fasteners after the cleaning cycle and prior to sterilization.

Failure to do so may cause components to loosen or disassemble during use

STERILIZATION

The following are GUIDELINES for product sterilization.

The Rultract® retractor assembly is a reusable instrument. It is supplied non-sterile and must be cleaned and sterilized prior to initial use and all subsequent use.

This validated process should be considered as a guideline only. Time, temperature and other conditions required for sterilization may vary according to type of sterilizer, cycle design, wrapping material, and/or other hospital practices.

Sterilization containers must be validated by their manufacturer for use in sterilization process. Validated cycles should be indicated in the container's Instructions for Use.

You must validate your own sterilization practice when it differs from the Instructions for Use provided by the device, container or sterilizer manufacturer.

RULTRACT® INSTRUCTIONS FOR USE—STERILIZATION PARAMETERS

Guidelines for Sterilization :

CAUTION: Reassemble prior to sterilization. See pages 41-43.

Cable should be wound on spool prior to sterilization leaving approximately 1 1/2 to 2 inches exposed.

The instruments may be sterilized by the following steam sterilization methods: Prevacuum and steam (gravity) wrapped or by using a rigid container system.

The following cycles were verified utilizing a combination of wrapped metal instruments or metal instruments in a common rigid container system with a mass up to 40 pounds (18 kg).

The wrapped instruments were wrapped with non-woven single use Steriwrap™.

Option 1: Wrapped Instruments or Instruments in Rigid Container System:

Pre-vacuum Sterilization Parameters
(Minimum time and temperature):
Temperature 132°C (270°F)
Exposure Time 4 minutes
Drying Time 30 minutes

Option 2: Wrapped Instruments or Instruments in Rigid Container System:

Steam (Gravity) Sterilization Parameters
(Minimum time and temperature):
Temperature 121° C (250°F)
Exposure Time 30 minutes
Drying Time 30 minutes

DO NOT remove fasteners or roll pins for cleaning and sterilization.

RULTRACT® INSTRUCTIONS FOR USE PREPARE FOR STERILIZATION

RATCHET/RAKE FASTENERS: CHECK FOR TIGHTNESS AFTER THE CLEANING CYLCE

PRIOR TO STERILIZATION

- ** 4 pcs 4100-33 Rake Clamp Screw to mount Rake Clamps to Rake Plate. (4100-52)
- ** 2 pcs 4100P-05 Cover Plate Screw to retain the Cover Plate on the Gearbox. (4100-50)
- ** 1 pc 4100-15 Spool Cap Nut to retain Spool Cap Assembly. (4100-51)
- ** 1 pc 4100P-11 Cable Access Plate Screw to retain Cable Access Plate. (4100-51)
- ** 1 pc 4100-03A Cable Set Screw to retain Cable in hub. (4100-51)

The following two items should not be removed. If these fasteners are removed a bolt retaining compound must be reapplied.

- ** 1 pc 4100-18 Crank Handle Screw to mount Crank Handle to Crank Arm. (4100-53)
- ** 1 pc 4100P-08 Crank Arm Screw to mount Crank Arm to Ratchet Shaft. (4100-53)

CAUTION: ** Check and tighten all fasteners on the Ratchet/Rake Assembly.

Failure to do so may cause components to loosen or disassemble during use.

CAUTION: ** Do not remove Roll Pins *(4100P-16). (4100-50)

4100-50 Gear Box Assembly

4100-52 Rake Plate Assembly

4100-53 Crank Handle Assembly

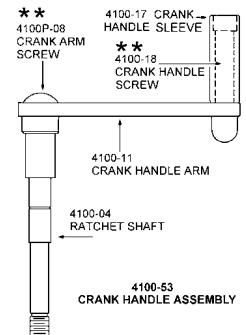
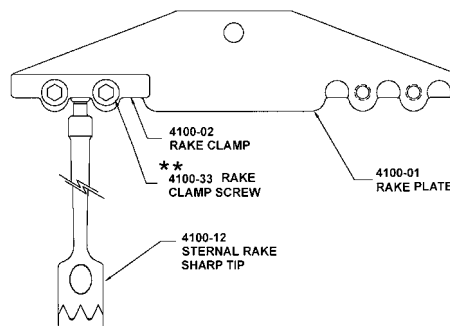
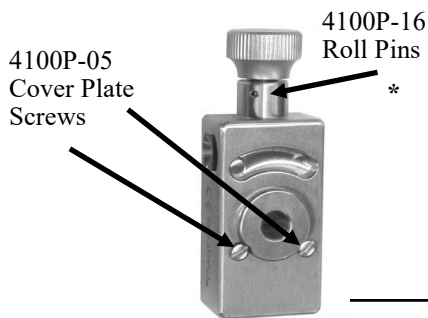

4100-51 Spool Cap Assembly Rake

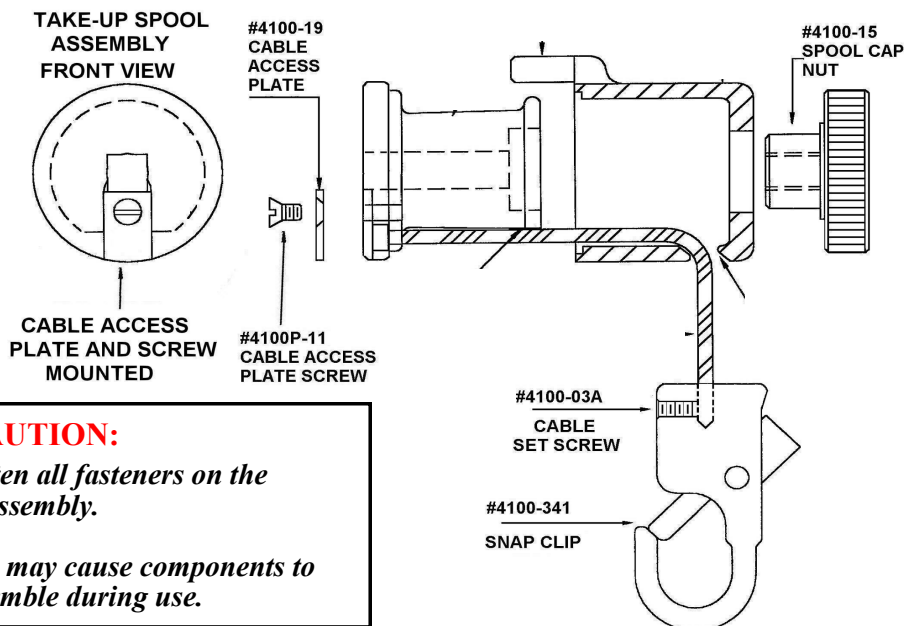

CAUTION:

Check and tighten all fasteners on the Ratchet/Rake Assembly.

Failure to do so may cause components to loosen or disassemble during use.

RULTRACT IFU SYSTEM COMPONENTS - PREPARE FOR STERILIZATION

DO NOT REMOVE RETAINING SCREWS

Sterilization: Clamp

- Do not disassemble for cleaning or sterilization.
- Do not remove retaining screw(s).**
- Do not open or close handle (s) completely.
- Jaws should be partially opened.
- Jaws and handles should have free movement.

Sterilization: Tilting Top Posts and Rotating Extender Bar

- Do not disassemble for cleaning or sterilization.
- Do not remove retaining screw (s).**
- Do not open or close knobs completely.
- Loosen knobs for partial separation.
- Sections and knobs should have free movement.

COMBINATION CLAMP
SCRUB/CIRCULATOR
APPLIED

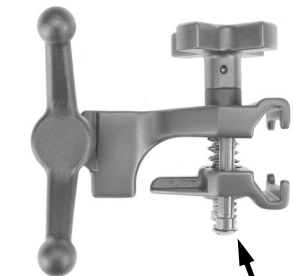

Retaining Screw **

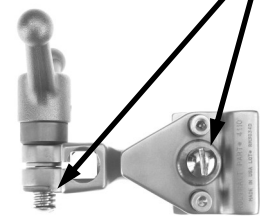

SCRUB
APPLIED
CLAMP



**

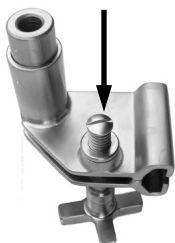

CIRCULATOR
APPLIED
CLAMP

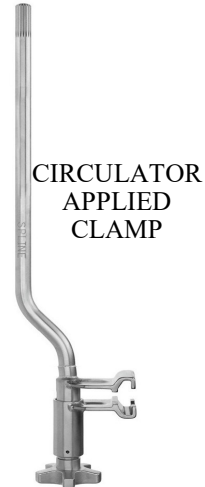

**



DO NOT REMOVE
RETAINING SCREWS



TILTING
POST

**

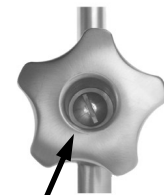

Retaining
Screw **
Part Number
4110P-12

DO NOT REMOVE
RETAINING SCREWS

ROTATING EXTENDER BAR



Retaining
Screw **

WARNING: Removal of retaining screw (s)** (4110P-12) will cause device to come apart. This will result in failure during use.

STERILIZATION: Resternotomy Rake Plates

- **No disassembly required**

4100-52RDL

4100-52RDM

4100-52RDS

4100-52RDH

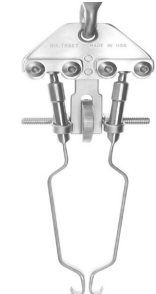
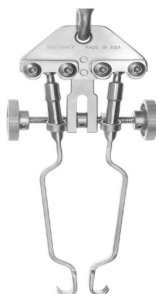

- Do not disassemble for cleaning or sterilization..

- Do not remove Rake Clamp screws.**
- Do not open or close knobs completely.
- Sections and knobs should have free movement.

**

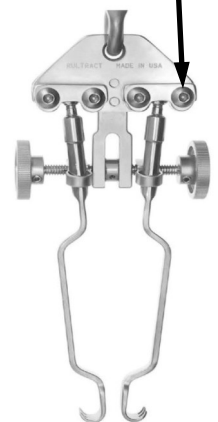

DO NOT
REMOVE
RAKE CLAMP
SCREWS

IN PREPARATION FOR STERILIZATION, YOU MUST REASSEMBLE THE 5 PIECES SHOWN IN Fig. 01 BACK INTO THE RATCHET/RAKE ASSEMBLY, 4100-IMR-6, AS SHOWN IN Fig. 02

These 5 pieces need to be reassembled into this for Sterilization and use.

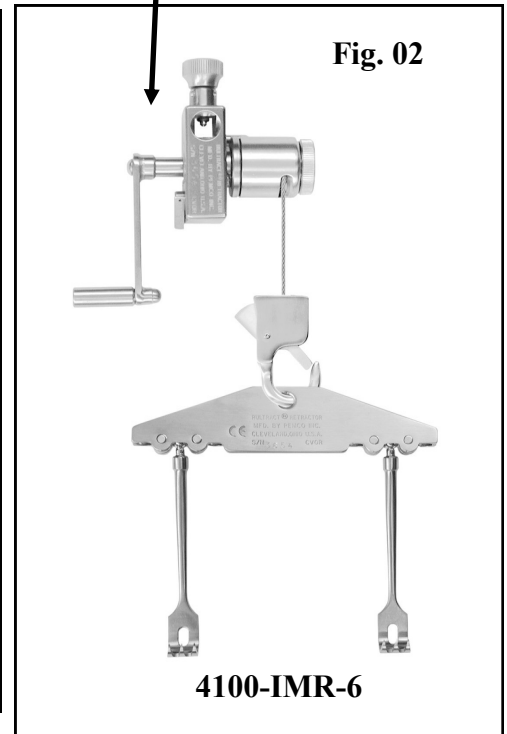
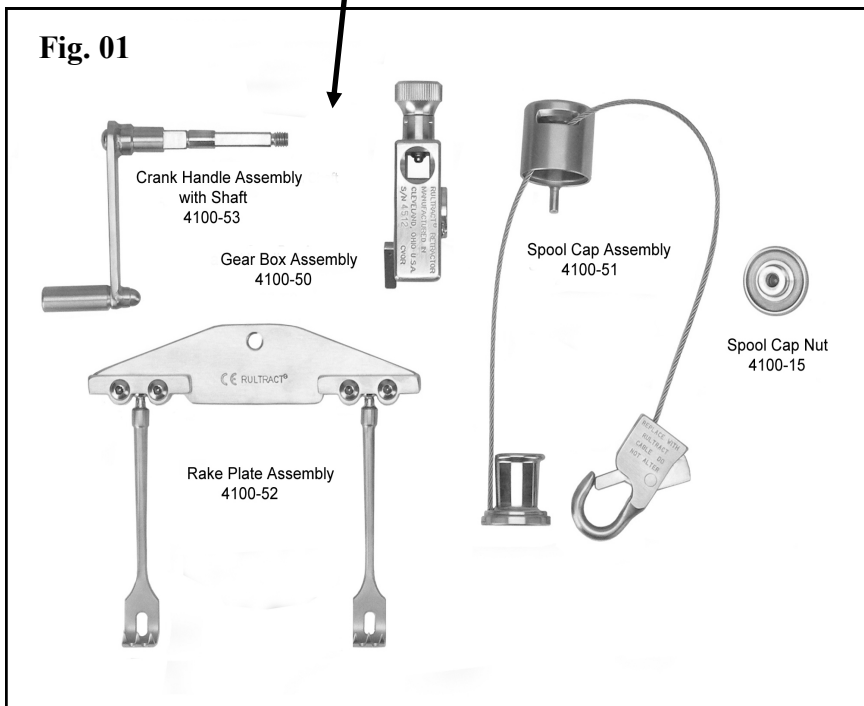

REASSEMBLE RATCHET FOR STERILIZATION AND USE

**STEP 1
INSTALL CRANK HANDLE:**

Slide the shaft of Crank Handle into square hole of Gearbox located above the Ratchet Lever (Fig. 01). **Note:** Both squared sections of the shaft must be completely inserted and flush in gearbox (Fig. 02).

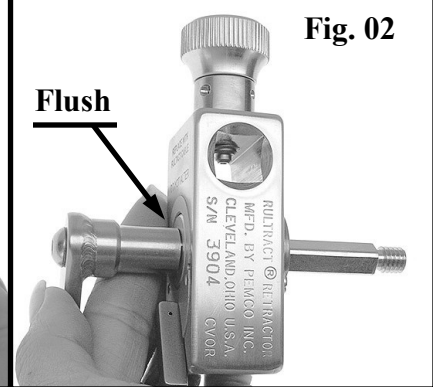
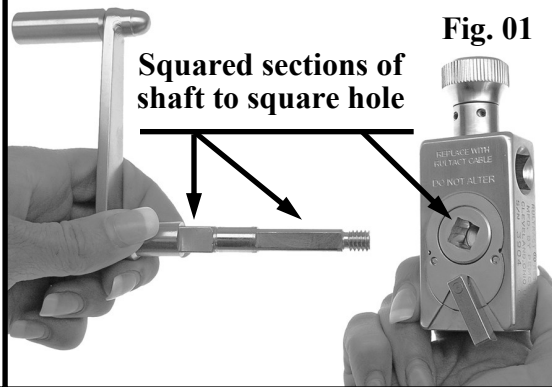

STEP 2 REASSEMBLE SPOOL AND SPOOL CAP: Align the Cable Guide with the flat surface of the Spool (Fig. 03). Slide Spool and Spool Cap together (Fig. 04).

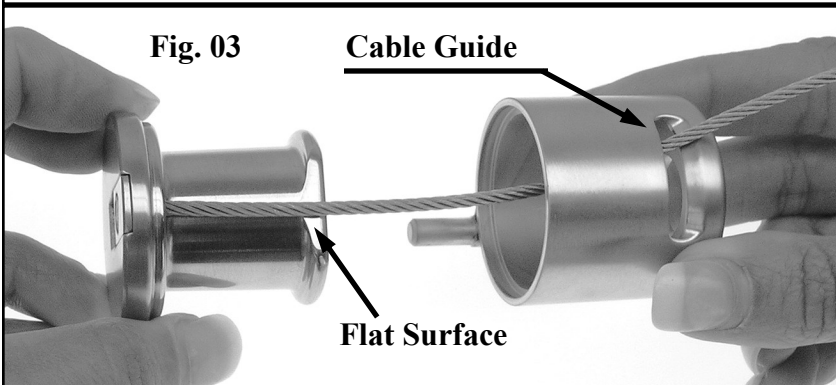

STEP 3 SPOOL CAP ASSEMBLY: While holding the Gearbox and Crank Handle together, line up Spool Cap Pin with the groove in the Gearbox. Slide the Spool Cap Assembly onto the shaft (Fig. 05). Spool Cap Pin must be inserted into groove of Gearbox. While holding Crank Handle Assembly and Gearbox firmly, screw the Spool Cap Nut onto the shaft by turning clockwise. **Hand tighten securely** (Fig. 06).

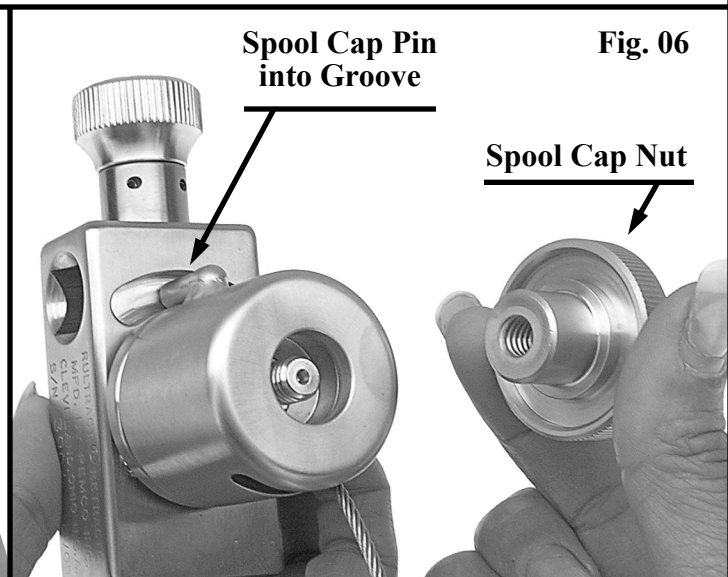
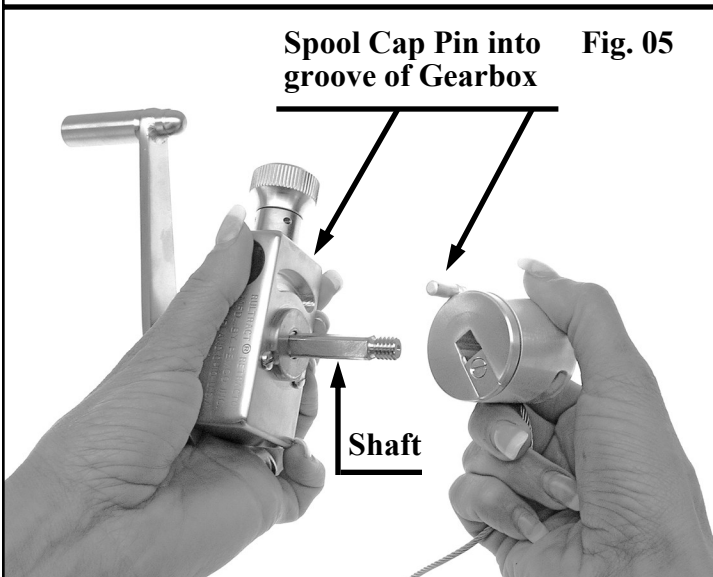

RULTRACT® INSTRUCTIONS FOR USE PREPARE FOR STERILIZATION

STEP 4 TEST WINDING FUNCTION:

Allow rake plate to hang freely**. Weight of Rake Plate allows for proper alignment of Cable on Spool. Total length of exposed, unwound Cable is approximately 18 inches (Fig. 25). Note: Leave one to two inches of Cable exposed to prevent flexing of Cable on Cable Guide at insertion site (Fig. 26). This position protects the Cable from kinking and allows gas or steam to penetrate during sterilization.

DEMONSTRATION
PROPER ALIGNMENT OF
CABLE ON SPOOL WHEN
WOUND CORRECTLY.
Shown without Spool Cap

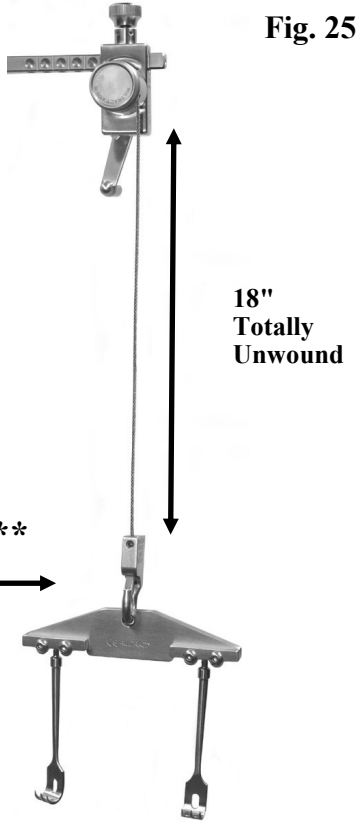

Fig. 25

18"
Totally
Unwound

Allow Rake Plate to
Hang Freely while
winding

**

Fig. 26

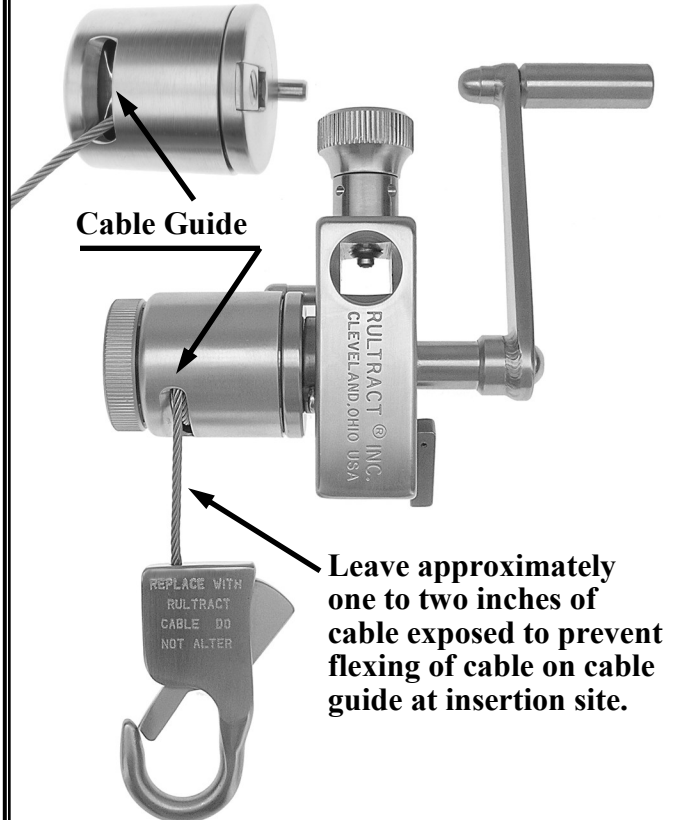

Cable Guide

Leave approximately
one to two inches of
cable exposed to prevent
flexing of cable on cable
guide at insertion site.

Your Rultract Ratchet
Rake Assembly is now
completely reassembled
and ready for Sterilization
and use

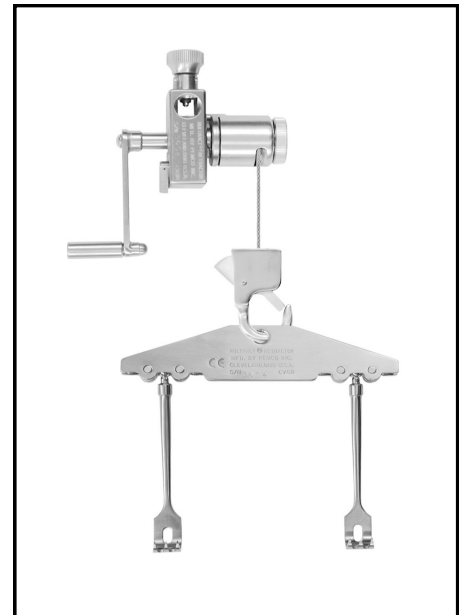

Rultract Inc. 5663 Brecksville Rd. Cleveland, Ohio 44131 U.S.A.
Email: rultract@rultract.com Website: www.rultract.com

Rultract® Skyhook Retractor Parts List

Part #	Part Description	Part #	Part Description
4100-IMR-6	Ratchet/Rake Assembly with Snap Clip	4100-59-07	Coupler Assembly
4100-IMR-41	Ratchet Assembly with Snap Clip	4100-59-07B	Coupler Bar
4100-02	Rake Plate Clamp	4100-59-08	Coupler Assembly
4100-341P	Snap Clip Pack w/ Cable	4100-59-08B	Coupler Bar
4100-03A	Cable Set Screw	4100-59-11	Coupler Assembly
4100-04	Ratchet Shaft	4100-59-11B	Coupler Bar
4100-06A	Take Up Spool	4100-59-03	Coupler Tube Assembly
4100-07B	Gearbox	4100-60	Minimally Invasive Rake Set
4100-08	One Piece Post	4100-60A	Minimally Invasive Rake
4100-11	Crank Arm	4100-60B	Minimally Invasive Rake
4100-12	Sternal Rake, Sharp Tip	4100-60C	Minimally Invasive Rake
4100-12D	Sternal Rake, Dull Tip	4100-60D	Minimally Invasive Rake
4100-12R	Sternal Ring Rake, Sharp Tip	4100-60AS	Pediatric Rake
4100-12RD	Sternal Ring Rake, Dull Tip	4100-60P-01	Pediatric Rake
4100-15	Spool Cap Nut	4100-60P-02	Pediatric Rake
4100-15A	Spool Cap	4100-60P-03	Pediatric Rake
4100-17	Crank Handle Sleeve	4100-60P-04	Pediatric Rake
4100-18	Crank Handle Screw	4100-60P-05	Pediatric Rake
4100-19	Cable Access Plate	4100-60P-06	Pediatric Rake
4100-20	Cable	4100-70	Xiphoid Rake
4100-20SP	Cable Replacement Single Pack	4100-71	Xiphoid Rake
4100-20P	Cable Replacement 3 Pack	4100-72	Xiphoid Rake
4100-28C	Square Tip Double Bend Bottom Post	4100-73	Xiphoid Rake
4100-28CP	Square Tip Offset Bottom Post	4100-74	Xiphoid Rake
4100-28CS	Spline Tip Double Bend Bottom Post	4100-75	Xiphoid Rake
4100-32A	Square Top Post, Standard Length	4100-77L	Sternal Rake, Large
4100-32AL	Square Top Post, Extended Length	4100-77M	Sternal Rake, Medium
4100-32ALS	Spline Top Post, Extended Length	4100-77S	Sternal Rake, Small
4100-32AP	Square Offset Top Post	4100P-05	Ratchet Cover Plate Screw
4100-32AS	Spline Top Post, Standard Length	4100P-08	Crank Arm Screw
4100-32AST	Spline Tilting Top Post	4100P-11	Cable Access Plate Screw
4100-32AT	Square Tilting Top Post	4100P-12	Large Allen Wrench
4100-32C	Square Tip Bottom Post with Collar (Round Base)	4100P-13	Small Allen Wrench
4100-32CS	Spline Tip Bottom Post with Collar (Square Base)	4100P-25	Rotating Extender Bar Spring
4100-32ST-06A	Knob Assembly	4100P-26	Tilting Post Spring
4100-33	Rake Clamp Screw	4110	Round Base Combination Clamp
4100-33P	Rake Clamp Screw Pack	4110-03A	Cross Handle Assembly
4100-39R	Riser Extender Bar with Cross Square	4110-04A	Wing Handle Assembly
4100-39S	Extender Bar with Cross Square	4110-17	Lower Jaw Assembly
4100-39TS	Rotating Extender Bar with Cross Square	4110P-05	Clamp Spring
4100-39TS-07A	Knob Assembly	4110P-12	Handle Retaining Screw
4100-50	Gearbox Assembly	4110P-14	Combination Clamp Spring (2019 and newer)
4100-51	Spool Cap Assembly	4110P-15	Combination Clamp Shoulder Bolt
4100-52	Sternal Rake Plate Assembly, Sharp Tip	4110S	Square Base Combination Clamp
4100-52D	Sternal Rake Plate Assembly, Dull Tip	4150	Square Tip, Double Bend Post/Clamp, Scrub Applied
4100-52RDH	Lift Spreader Plate Assembly, Hook	4150S	Spline Tip, Double Bend Post/Clamp, Scrub Applied
4100-52RDL	Lift Spreader Plate Assembly, Large	4160	Square Tip, Double Bend Post/Clamp, Circulator Applied
4100-52RDM	Lift Spreader Plate Assembly, Medium	4160-09A	5 Point Handle Assembly 10-TPI
4100-52RDS	Lift Spreader Plate Assembly, Small	4160-09B	5 Point Handle Assembly 8-TPI
4100-53	Crank Handle Assembly with Shaft	4160S	Spline Tip, Double Bend Post/Clamp, Circulator Applied
4100-54	Ratchet Cover Plate Assembly		

Rultract Inc. 5663 Brecksville Rd. Cleveland, Ohio 44131 U.S.A.
 Email: rultract@rultract.com Website: www.rultract.com

PROPER SERVICING AND REPAIR OF YOUR RULTRACT RETRACTOR SYSTEM

WARNING: -

USING OUTSIDE SERVICE VENDORS TO SERVICE/REPAIR YOUR RULTRACT RETRACTOR SYSTEM:

Using outside service vendors to service/repair your Rultract retractor system will release Rultract from all liability associated with the use of the system, void all current warranties, and could potentially put the hospital, operating room staff and patient at risk.

Rultract is the only authorized service center for the Rultract Retractor System. Outside service vendors are not authorized to service or repair the Rultract Retractor System and do not have access to all Rultract OEM replacement parts.

Use only Rultract OEM parts and service as provided at the factory authorized Rultract service center. Failure to do so could put the hospital, operating room staff and patient at risk.

HANDLING OF RULTRACT® RETRACTOR CABLE

The Rultract Retractor System uses a specific cable which holds the Snap Clip and Rake Plate. If the proper OEM pieces are not used and the pieces are not serviced in regular intervals by a factory trained technician, they could separate during surgery possibly causing serious injury.

CAUTION:

**** Always allow rake plate to hang freely when winding Cable.** The weight of Rake Plate allows for proper alignment of Cable on Spool. Failure to allow the Rake Plate to hang freely may cause the Cable to kink during winding. Leave approximately one to two inches of Cable exposed to prevent flexing of Cable on Cable Guide at insertion site.

CAUTION:

Always insert spool cap pin into the groove of the gearbox. Failure to do so may result in disassembly or damage to the unit.

Contact Rultract at service@rultract.com or 888-550-5695 to schedule service/repair or with questions concerning routine maintenance and service.

SERVICE INTERVAL: Complete factory service of your Rultract Skyhook Retractor System (including a cable change):

****If using a surgical device tracking system to track cases, i.e. Censitrac: 400 cases.**

****If not using a surgical device tracking system to track cases, i.e. Censitrac: Every 12-24 months dependent on frequency of use.**

WARNING:

Cables worn or damaged through mishandling prior to the factory service interval, must be replaced with a new Rultract® cable. Do not attempt to repair, cut, alter or modify the cable in any way. **Cutting and reattaching the cable will cause it to weaken and fray. This will result in failure during use.**

REPLACEMENT: Rultract Ratchet Assemblies and Rake Plate Assemblies purchased prior to 2000, with no OEM maintenance history or relevant product update history, require replacement.

WARNING: Any modification or alteration to a Rultract® product by user will void all warranties and release Rultract® from any liability

This page intentionally left blank

This page intentionally left blank



INSTRUCTIONS FOR USE

Rultract, Inc.

5663 Brecksville Rd. Cleveland, Ohio 44131-1593 U.S.A.

PH:(888) 550-5695

E-Mail: rultract@rultract.com Website: www.rultract.com



Rultract, Inc. 5663 Brecksville Rd.
Cleveland, Ohio 44131 U.S.A.